

advanced FLOW engineering

Cold Air Intake System

Instruction Manual P/N: 56-70061D / 56-70061R

Make: Lexus
Make: Lexus

Model: IS350
Model: IS300

Year: 2021-2024
Year: 2021-2024

Engine: V6-3.5L
Engine: V6-3.5L



- Please read the entire instruction manual before proceeding.
- Ensure all components listed are present.
- If you are missing any of the components, call customer support at 951-493-7185.
- Ensure you have all necessary tools before proceeding.
- Do not attempt to work on your vehicle when the engine is hot.
- Retain factory parts for future use.

Label	Qty.	Description	Part Number
A	1	Air Filter (Pro 5R) For 56-70061R	24-91144
A	1	Air Filter (Pro DRY S) For 56-70061D	21-91144
B	1	Tube	05-5670061B1
C	1	Housing	05-5670061B2
D	1	Coupling, Silicone Reducer: (3.25" x 3.12") ID x 3'L	05-01599
E	2	Clamp, #048 (2-9/16" - 3-1/2 ")	03-50007
F	1	Bumper, Rubber: 1/2" ID x 1" OD	03-50769
G	2	Screw, M4 x 8mm	03-50491
H	1	Plug, Air Box	05-01527

Installation will require the following tools:

Socket set, extension, ratchet, T-20 Torx screwdriver, Phillips screwdriver, Pliers

Warranty Information available at: <https://afepower.com/contact#warranty>

Emissions Disclaimer: This product is not currently CARB exempt and is not available for purchase in California or for use on any vehicle registered with the California Department of Motor Vehicles.

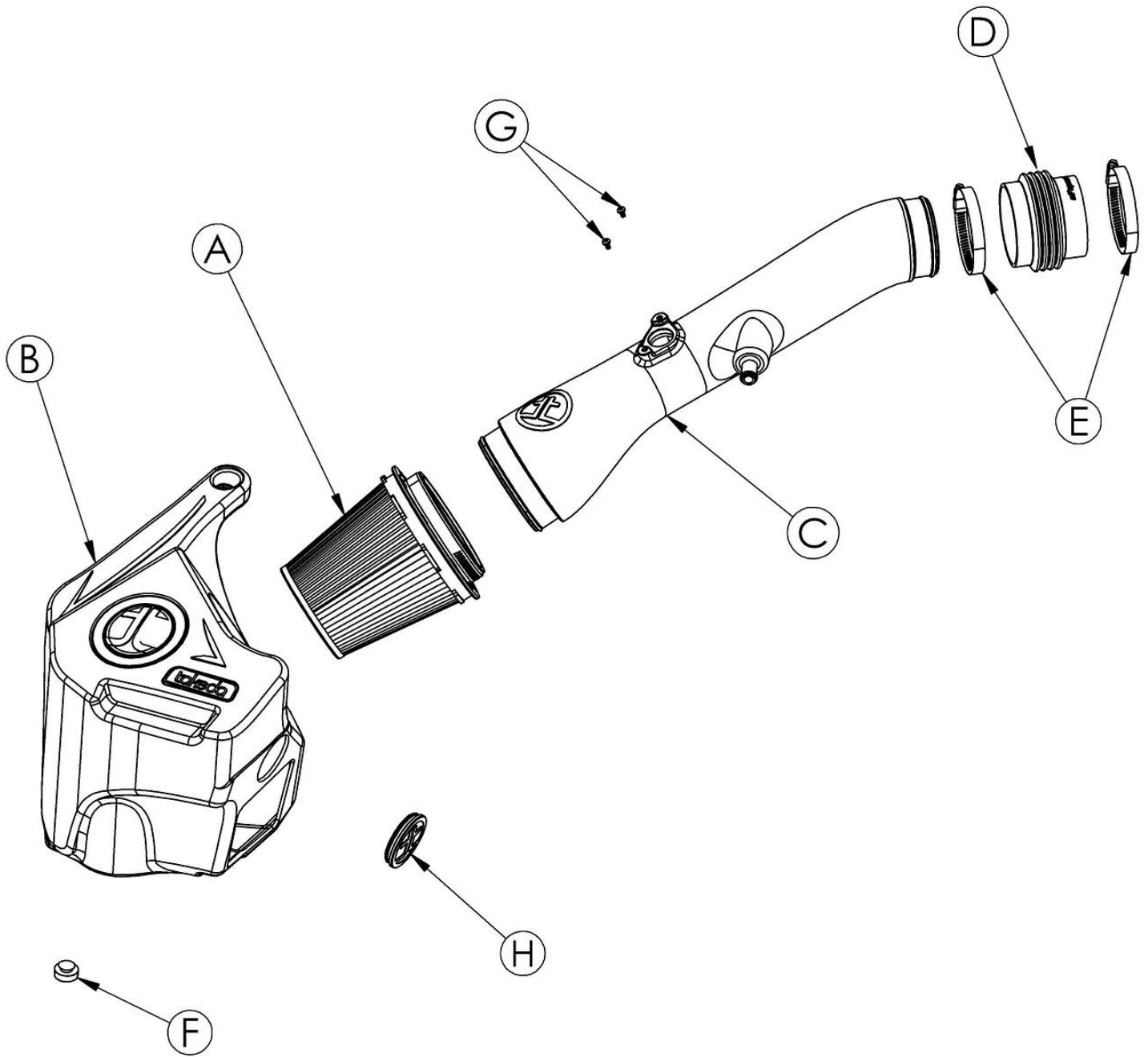

**Figure A****Refer to Figure A for Steps 1-2**

Step 1: Remove the engine cover.

Step 2: Remove the retaining clips holding the plastic cover and remove the cover.



Refer to Figure B for Steps 3-4

Step 3: Remove the bolt holding the factory scoop.

Step 4: Then remove the factory scoop from the engine bay by lifting it up.

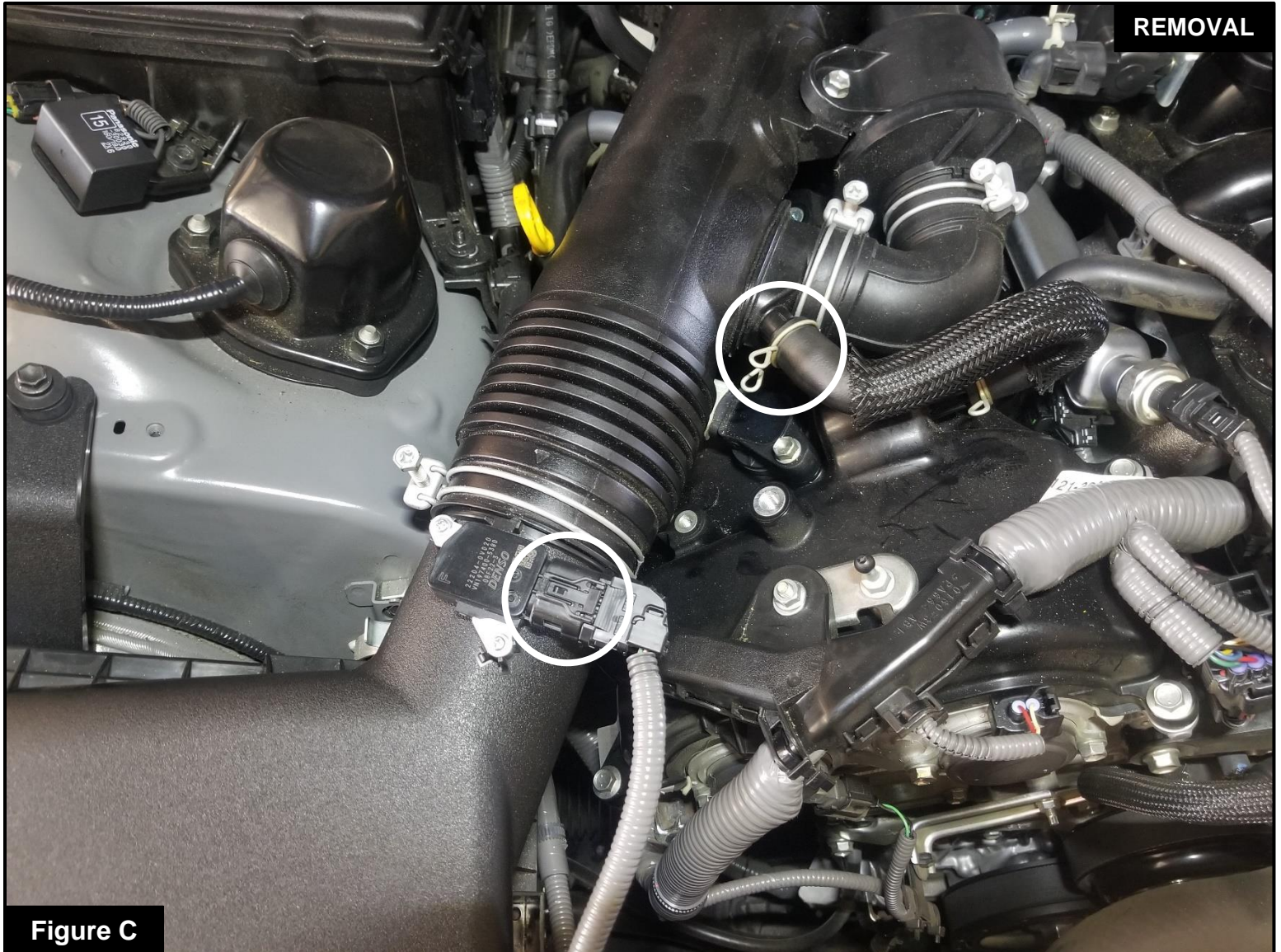

Figure C

Refer to Figure C for Steps 5-6

Step 5: Disconnect the Mass Air Flow (MAF) Sensor harness from the Mass Air Flow Sensor.

Step 6: Pinch the clip on the hose to disconnect it from the factory tube.

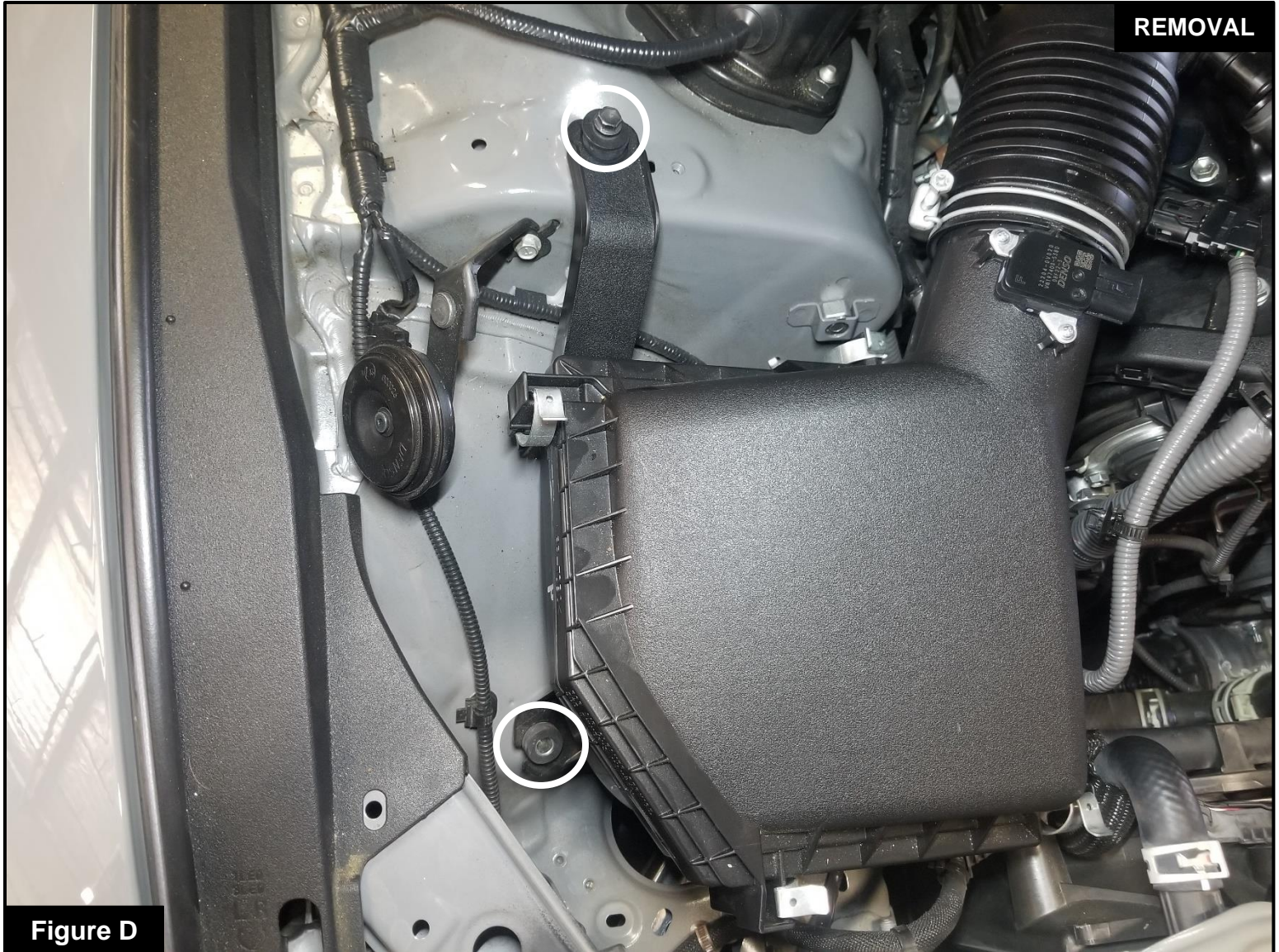

Figure D

Refer to Figure D for Step 7

Step 7: Remove the two (2) 10mm bolt holding the factory housing.

**Figure E****Refer to Figure E for Steps 8-9**

Step 8: Loosen the clamp at the throttle body.

Step 9: Then pull up on the factory housing and tube to remove as one piece out of the vehicle.

**Figure F****Refer to Figure F for Steps 10-11**

Step 10: Transfer the Mass Air Flow sensor from the factory housing to the Takeda tube and secure it with the supplied M4 screws.

Step 11: Place the supplied coupling onto the Takeda tube. Place the clamps on the coupling and tighten only the clamp on the tube side at this time.



Figure G

Refer to Figure G for Step 12

Step 12: Install the air filter into the housing by firmly pushing it into the housing until the filter tabs lock it into place. Install the clamp on the filter, but do not tighten at this time.

Figure H

Refer to Figure H for Step 13

Step 13: This kit includes an optional plug to close off the auxiliary air inlet. Install the plug if you wish to close it off to only capture cold air from the factory inlet.

- Without the plug installed, the Takeda intake will capture the maximum air available. More airflow offers more power, yet some of this air is picked up from the inside the engine compartment and could be warmer air, which will affect the performance of the vehicle.
- The plug installed on the housing will block off any hot engine air entering the housing to make sure the coolest air available is directed into the engine. Intake noise will also be reduced is using the plug.



Figure I

Refer to Figure I for Step 14

Step 14: Transfer the grommet and metal sleeve from the factory housing into the Takeda housing.



Figure J

Refer to Figure J for Step 15

Step 15: Install the supplied bumper into the hole at the bottom of the Takeda housing.



Figure K

Refer to Figure K for Steps 16-19

Step 16: Install the assembled Takeda housing into the engine bay.

Step 17: Secure it by tightening the bolt removed at **step 7**.

Step 18: Reinstall the factory inlet scoop into the Takeda housing and secure it with the bolt removed at **step 3**.

Step 19: Then install the factory plastic cover and secure it with the clips removed at **step 2**.



Refer to Figure K for Steps 21-24

Step 21: Slip the Takeda intake tube into the air filter and over the throttle body. Align the tube, filter and coupling, then tighten all clamps.

Step 22: Reconnect the Mass Air Flow sensor harness to the Mass Air flow sensor.

Step 23: Reconnect the hose to the Takeda tube and secure it with the clamp removed at **step 6**.

Step 24: Make sure that all clamps and connections are secured. Your installation is now complete. Thank you for choosing Takeda USA!

NOTE: Check to ensure that all screws, clamps, and connectors are secure after 100-200 miles.



advanced FLOW engineering, inc.

Corona, CA 92879

<https://afepower.com/contact>