

advanced FLOW engineering Magnum FORCE Stage-2 Cold Air Intake System

Instruction Manual P/N: 54-13078D / 54-13078R

Make: Jeep
Make: Jeep

Model: Wrangler (JL)
Model: Gladiator (JT)

Year: 2018-2023
Year: 2020-2023

Engine: V6-3.6L
Engine: V6-3.6L



- Please read the entire instruction manual before proceeding.
- Ensure all components listed are present.
- If you are missing any of the components, call customer support at 951-493-7185.
- Ensure you have all necessary tools before proceeding.
- Do not attempt to work on your vehicle when the engine is hot.
- Retain factory parts for future use.

Label	Qty.	UoM	Description	Part Number
A1	1	Ea	Air Filter (Pro DRY S)	24-91203D
A2	1	Ea	Air Filter (Pro 5R)	24-91203R
B	1	Ea	Tube	05-5413078B1
C	1	Ea	Housing	05-5413078B2
D	1	Ea	Coupling, Silicone Bellows 3-1/4"ID x 3"L	05-01480
E	2	Ea	Clamp, 048	03-50007
F	1	Ea	Fitting, Vent Tube	05-01339
G	1	Ea	Grommet, Rubber Large	03-50167
H	1	Ea	Fitting, Intake Air Temp Sensor	05-01454
J	34.5	In	Seal, Trim: 3/4" Bulb	05-01507

Installation will require the following tools:

8mm nut driver or flat head screwdriver, 10mm socket and wrench, adjustable wrench, panel clip pliers or similar.

Warranty Information available at: <https://afepower.com/contact#warranty>

Emissions Disclaimer: This product is not currently CARB exempt and is not available for purchase in California or for use on any vehicle registered with the California Department of Motor Vehicles.

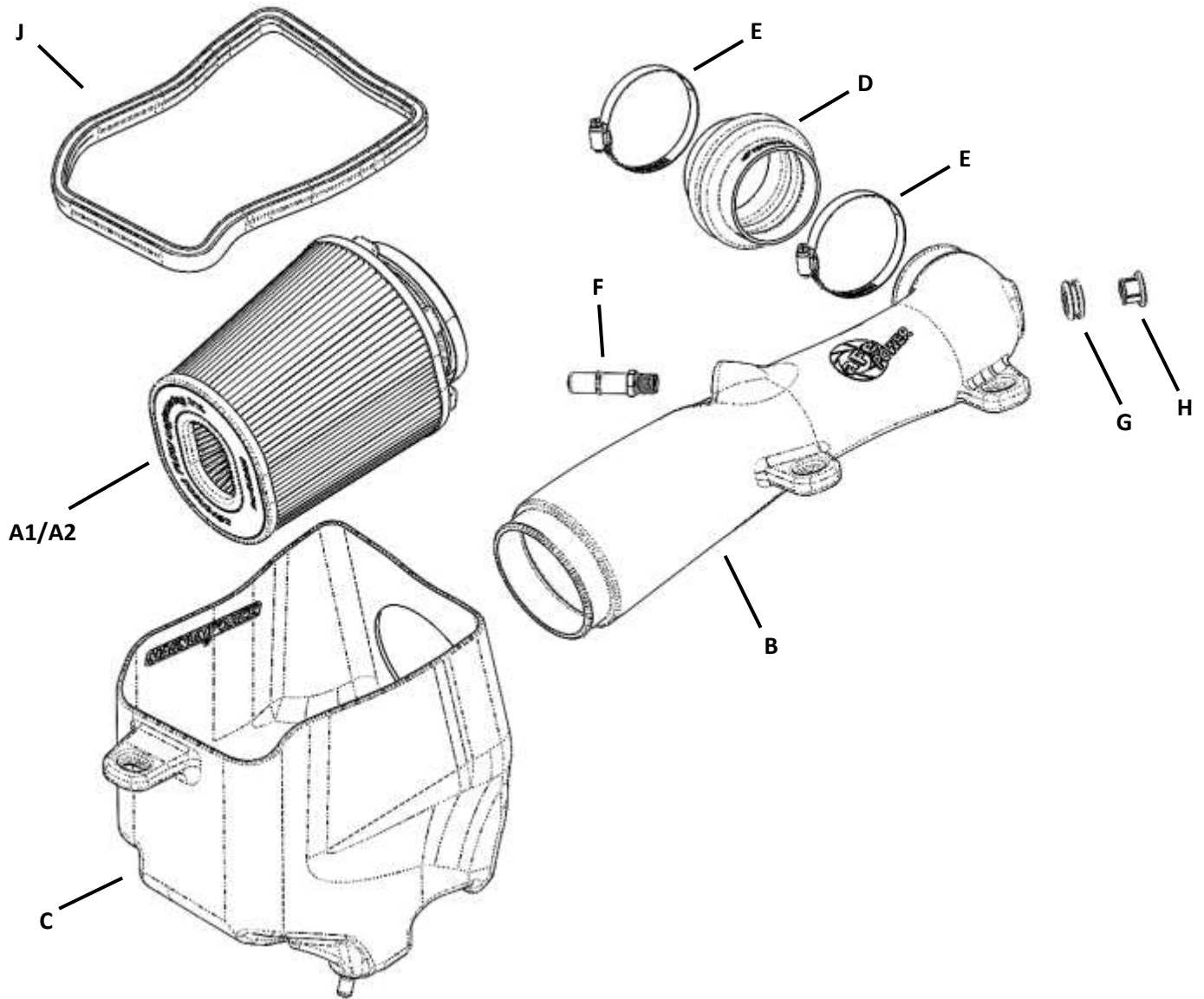



Refer to Figure A for Steps 1-2

Step 1: Using a 10mm socket and driver, remove the (3) screws (1) securing the OE intake to the vehicle.

Step 2: Using an 8mm nut driver, loosen the two clamps (2) on the intake tube.



Figure B

Refer to Figure B for Steps 3-5

Step 3: Disconnect the Crank Case Vent (CCV) line that is connected to the intake tube (3) by pushing on the grey clip and sliding the tube off the fitting.

Step 4: Disconnect the Intake Air Temperature (IAT) sensor (4).

Step 5: Remove the attaching clips for the IAT sensor harness and the coolant line (5) and move the harness out of the way for now.

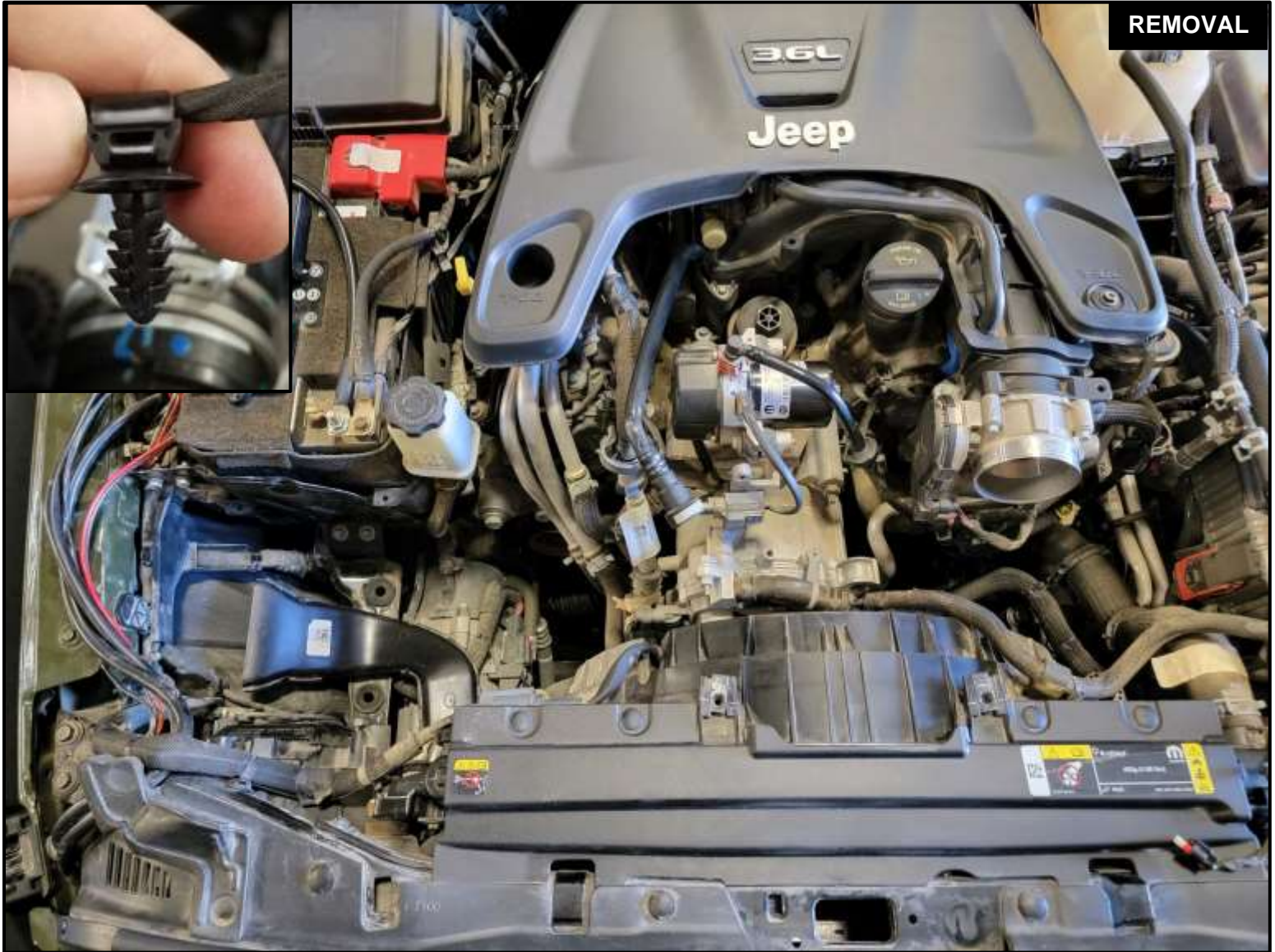

Refer to Figure C for Steps 6-8

Step 6: Remove the OE intake tube from the vehicle.

Step 7: Remove the OE housing from the vehicle by lifting straight upward. If the rubber grommets pop off with the housing, then remove them from the housing and place them back into the holes in the mounting bracket.

Step 8: If the attaching clips on the IAT sensor harness are bent out of shape, then repair them so that it looks like the clip shown in the small photo.

**Figure D****Refer to Figure D for Step 9**

Step 9: Install the new CCV fitting (6) into the threaded insert on the aFe POWER intake tube.

Note: *Liquid Loctite or Teflon tape should be used to provide a proper seal. Do not over tighten the fitting. Please note that this fitting is aluminum and can be scratched if serrated pliers are used.*

**Figure E****Refer to Figure E for Steps 10-13**

Step 10: Remove the IAT Sensor from the factory intake tube by lifting the locking tab, rotating the sensor a quarter-turn counterclockwise, and then pulling the sensor straight out.

Step 11: Install the large rubber grommet into the large hole on the aFe POWER intake tube.

Step 12: Install the supplied IAT Fitting into the large rubber grommet.

Step 13: Install the IAT Sensor (7) into the IAT Fitting, and rotate it clockwise a quarter-turn to lock it into place. Make sure the locking tab clicks past the retainer on the IAT Fitting.

Note: *The orientation of the sensor is not critical.*

**Figure F****Refer to Figure F for Steps 14-16**

- Step 14:** Remove the (2) two rubber mounting grommets and steel sleeves from the factory intake tube.
- Step 15:** Install the (2) two rubber mounting grommets and steel sleeves (8) into the aFe POWER intake tube as shown.
- Step 16:** Install the bellows coupling (9) onto the end of the tube and preinstall the two clamps onto the coupling. Do not tighten the clamps at this time.

**Figure G****Refer to Figure G for Steps 17-20**

Step 17: Remove the rubber mounting grommet and steel sleeve from the factory intake housing.

Step 18: Install the rubber mounting grommet and steel sleeve (10) into the aFe POWER intake housing as shown.

Step 19: Install the trim seal (11) around the top of the housing. Make sure to press down firmly all around the trim seal to ensure a good fit.

Step 20: Install the aFe POWER air filter into the housing and loosely install the clamp over the filter flange.

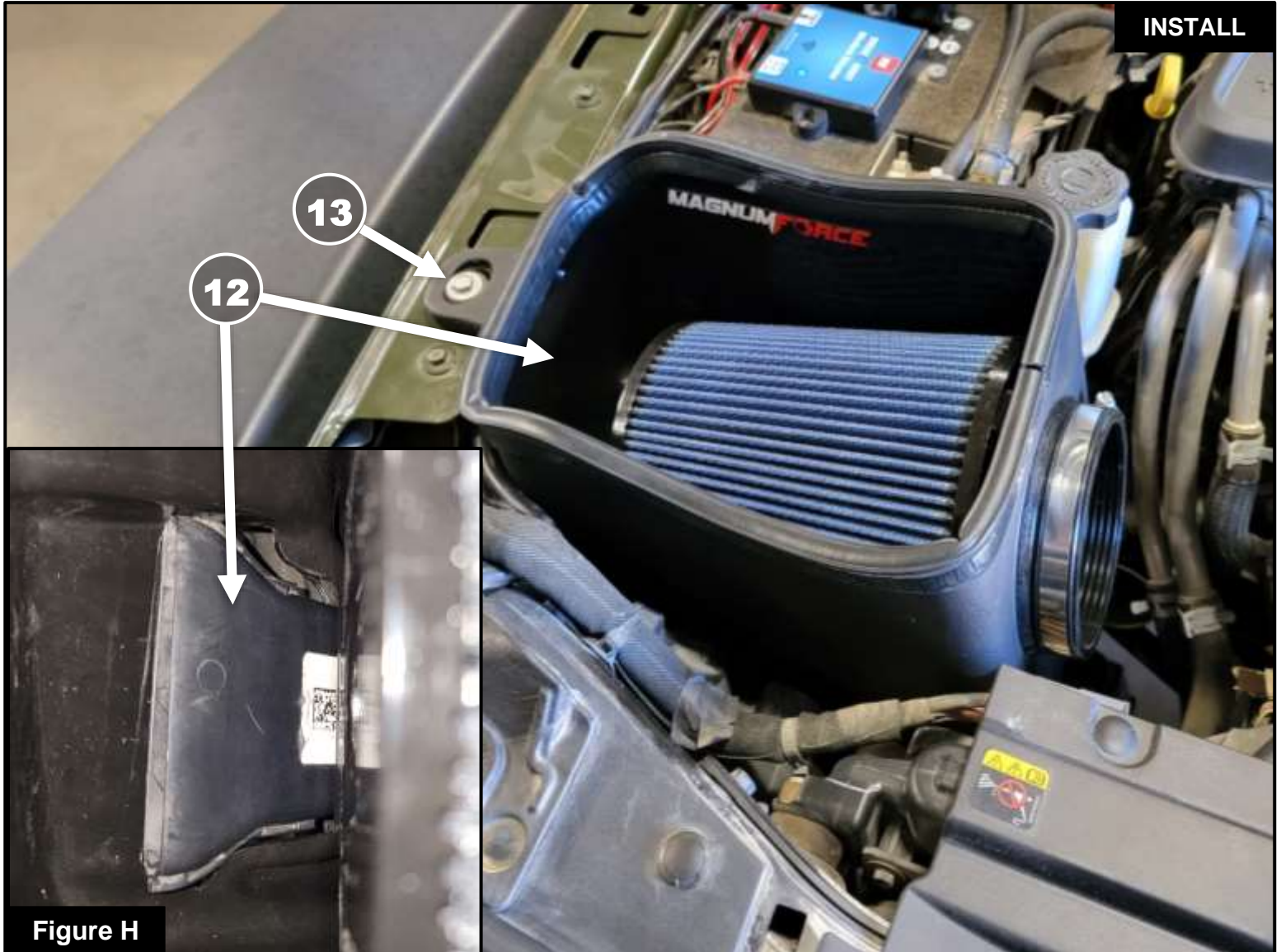

Figure H

Refer to Figure H for Steps 21-23

Step 21: Install the housing into the vehicle and make sure that the factory intake scoop (12) passes into the housing under the air filter .

Step 22: Press down firmly on the housing to lock the pegs into the rubber grommets under the housing.

Step 23: Secure the housing to the fender with the factory screw (13) .

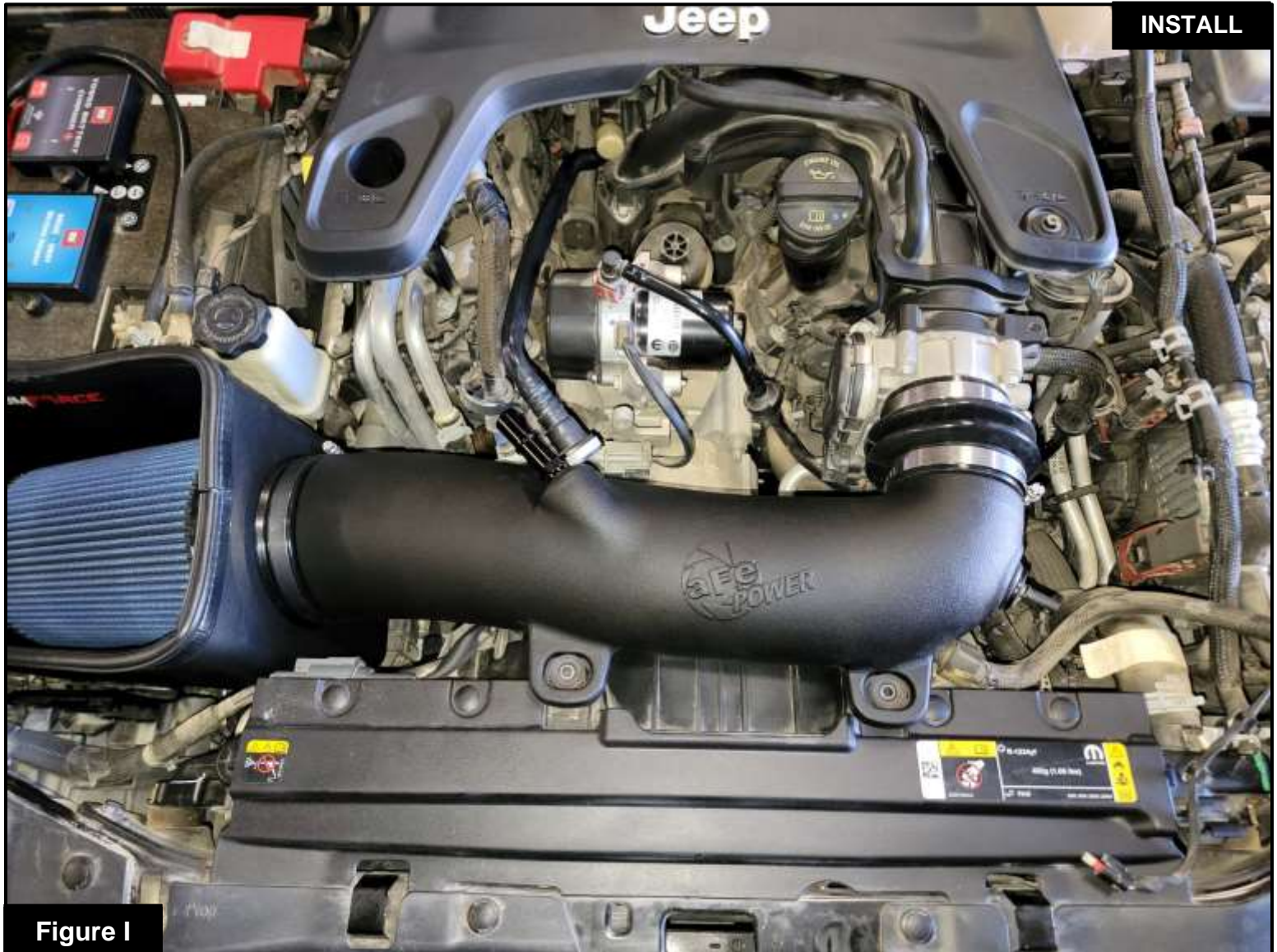

Figure I

Refer to Figure I for Steps 24-26

Step 24: Install the aFe POWER intake tube into the air filter first and then slide the coupler over the throttle body.

Step 25: Rotate the tube into position so that the mounting tabs sit flat on the fan shroud mounting brackets.

Step 26: Tighten all clamps at this time.

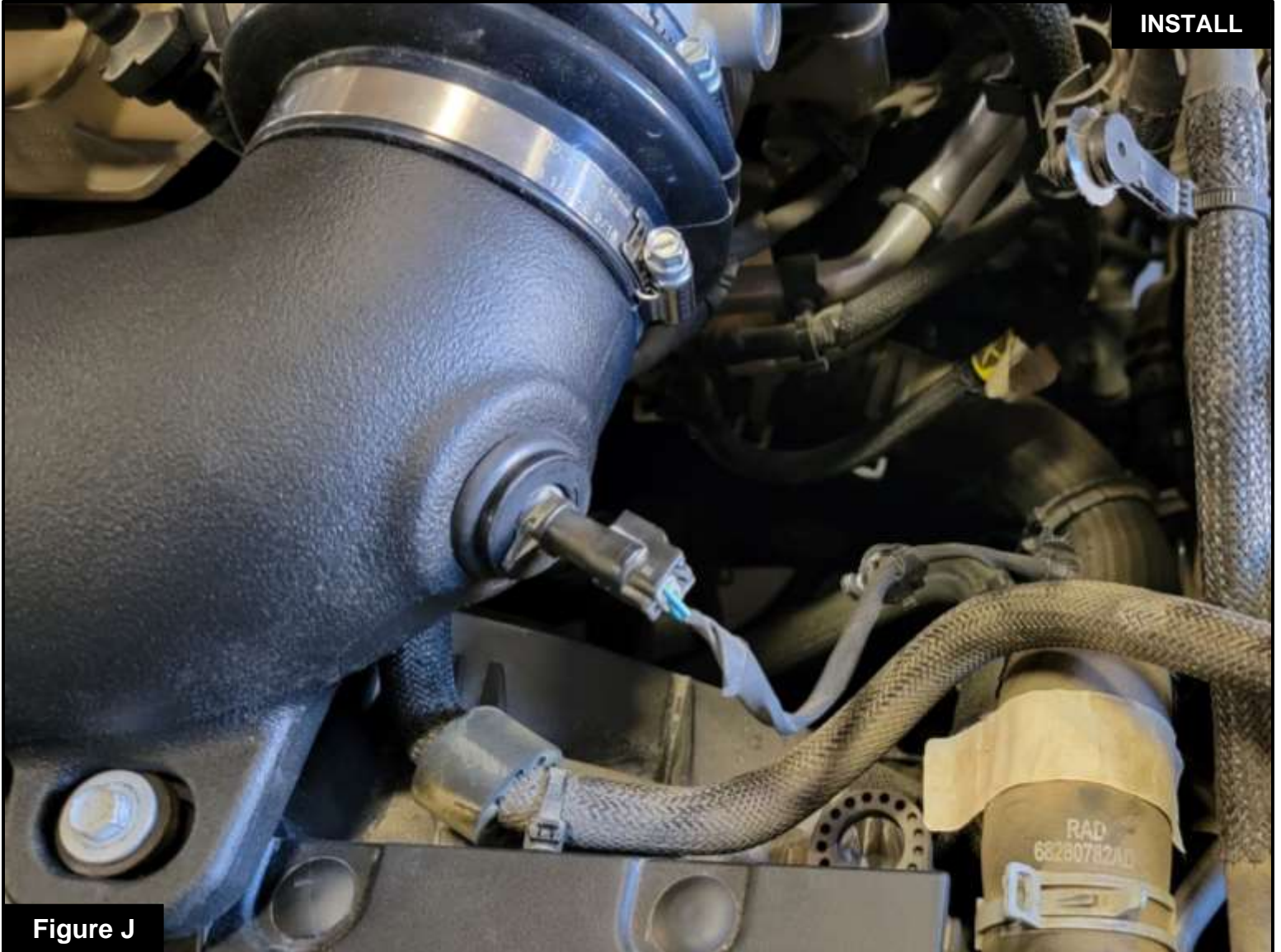
**Figure J****Refer to Figure J for Steps 27-28**

Step 27: Reroute the IAT harness so that it cannot be pinched or caught in the cooling fan. If preferred, use zip ties to secure the coolant hose and wire harness into place.

Step 28: Connect the IAT harness to the IAT sensor on the intake tube.

**Figure K****Refer to Figure K for Steps 29-30**

Step 29: Secure the intake tube to the fan shroud with the (2) two factory screws (15) .

Step 30: Reconnect the CCV line (16) to the new CCV Fitting on the aFe POWER intake tube.



Figure L

Refer to Figure L for Step 31

Step 31: Check all the components are tight and secure. Your installation is now complete. Thank you for choosing aFe POWER!

NOTE: Check all screws, clamps, and connectors are secure after 100-200 miles.



advanced FLOW engineering, inc.
252 Granite Street Corona, CA 92879
<https://afepower.com/contact>