



# **GT** **MOMENTUM**

**advanced FLOW engineering**

Cold Air Intake System

**Instruction Manual** P/N: 50-70111D/ 50-70111R

Make: Jeep

Model: Grand Wagoneer

Year: 2022-2023

Engine: V8-6.4L



- Please read the entire instruction manual before proceeding.
- Ensure all components listed are present.
- For technical support please call at 951-493-7185.
- Ensure you have all necessary tools before proceeding.
- Do not attempt to work on your vehicle when the engine is hot.
- Retain factory parts for future use.

Label	Qty.	Description	Part Number
A	1	Air Filter (Pro DRY S) for 50-70111D	21-91092
A	1	Air Filter (Pro 5R) for 50-70111R	24-91092
B	1	Tube	05-5070111B1
C	1	Housing	05-5070106B2
D	1	Coupling, Silicone Elbow (3-1/2" to 4") X 40Deg	05-01508
E	1	Clamp, #056	03-50009
F	1	Clamp, #060	03-50002
G	1	Grommet	03-50167
H	1	Fitting, Air Temperature Sensor	05-01454
J	1	Fitting, SAE 15.82 – 5/8" to 3/8" NPT	05-01339
K	1	Plug, Silicone	05-01429

**Installation will require the following tools:**

8mm nut drivers or sockets, socket wrench, adjustable wrench, flat-head screwdriver, and T20 torx bit.

Warranty information available at <https://afepower.com/contact#warranty>.

**Emissions Disclaimer:**

This product is not currently CARB exempt and is not available for purchase in California or for use on any vehicle registered with the California Department of Motor Vehicles.

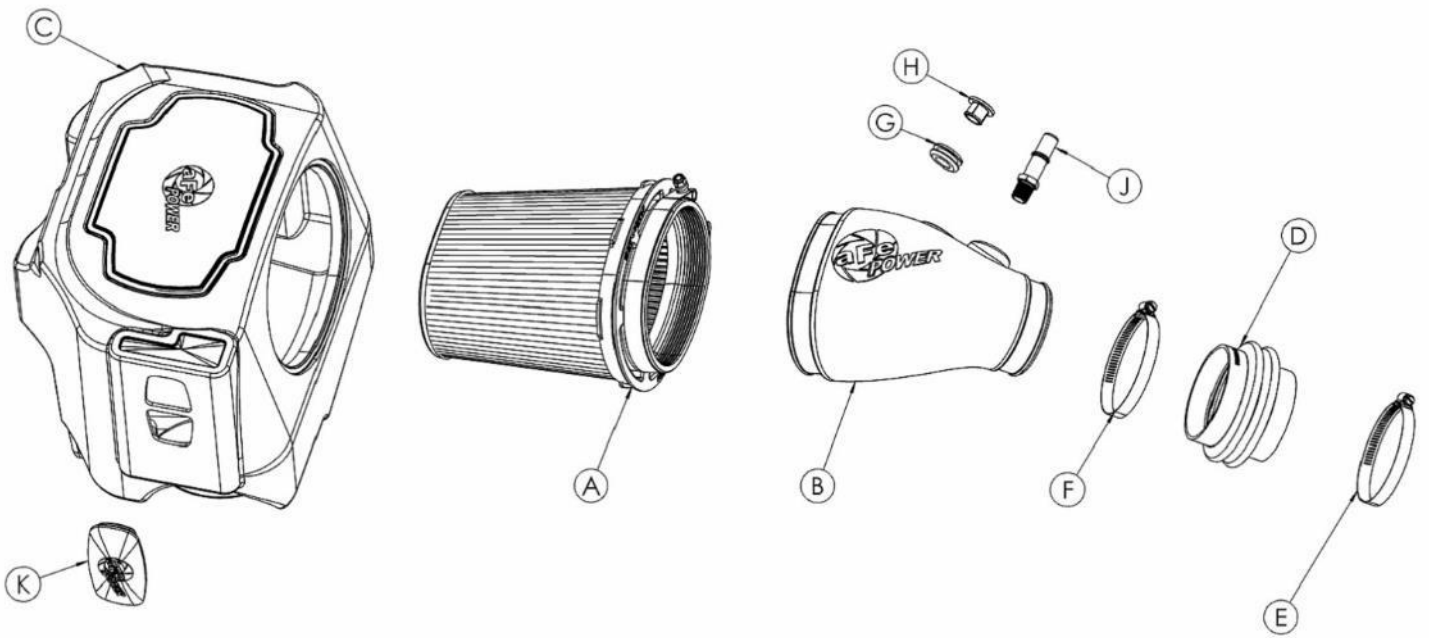



**Figure A**

**Refer to Figure A for Steps 1-2**

Step 1: Disconnect the crankcase breather hose from the factory tube by pushing on the grey tab of the quick-disconnect fitting.

Step 2: Disconnect the temperature sensor harness.



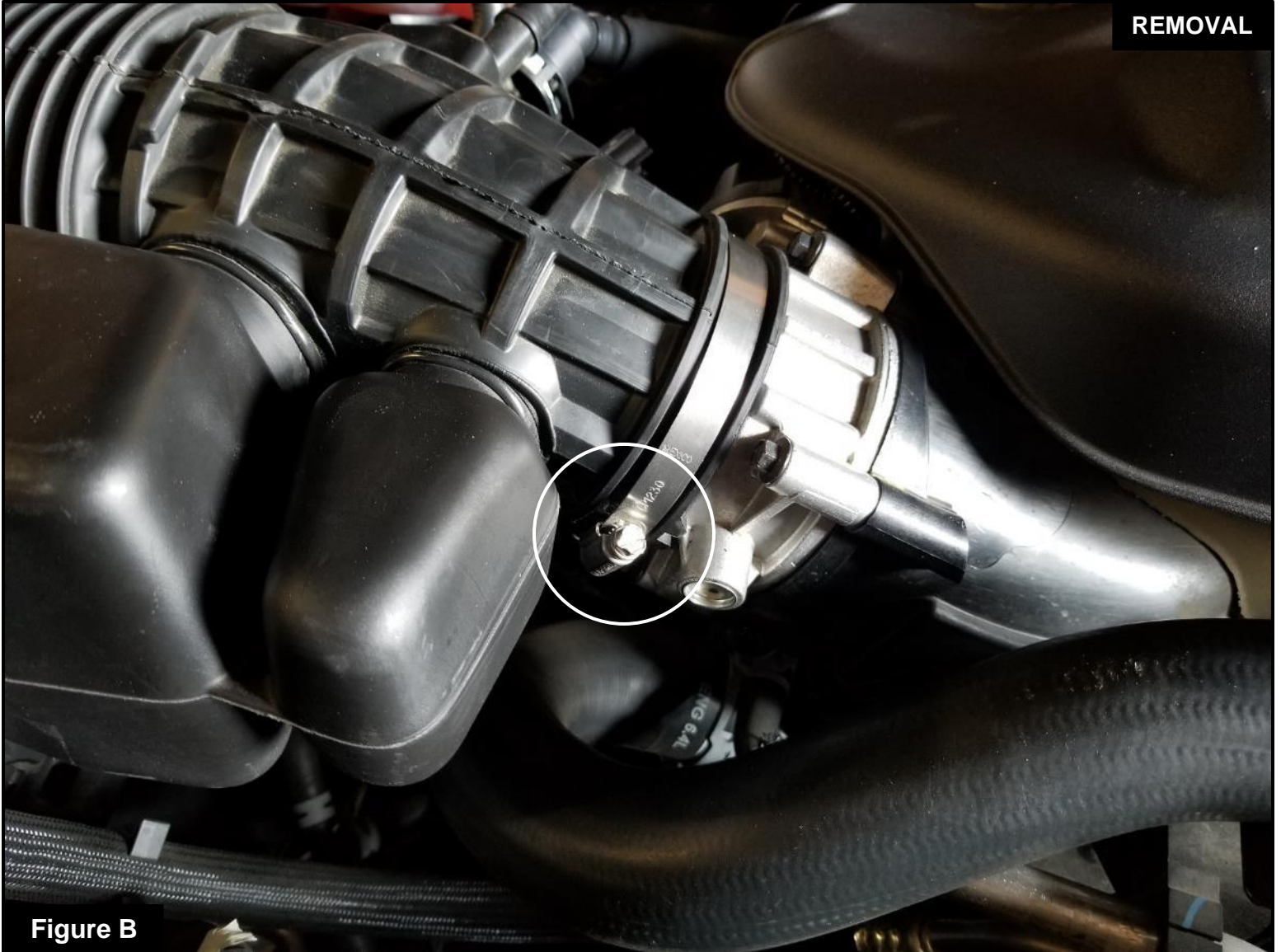
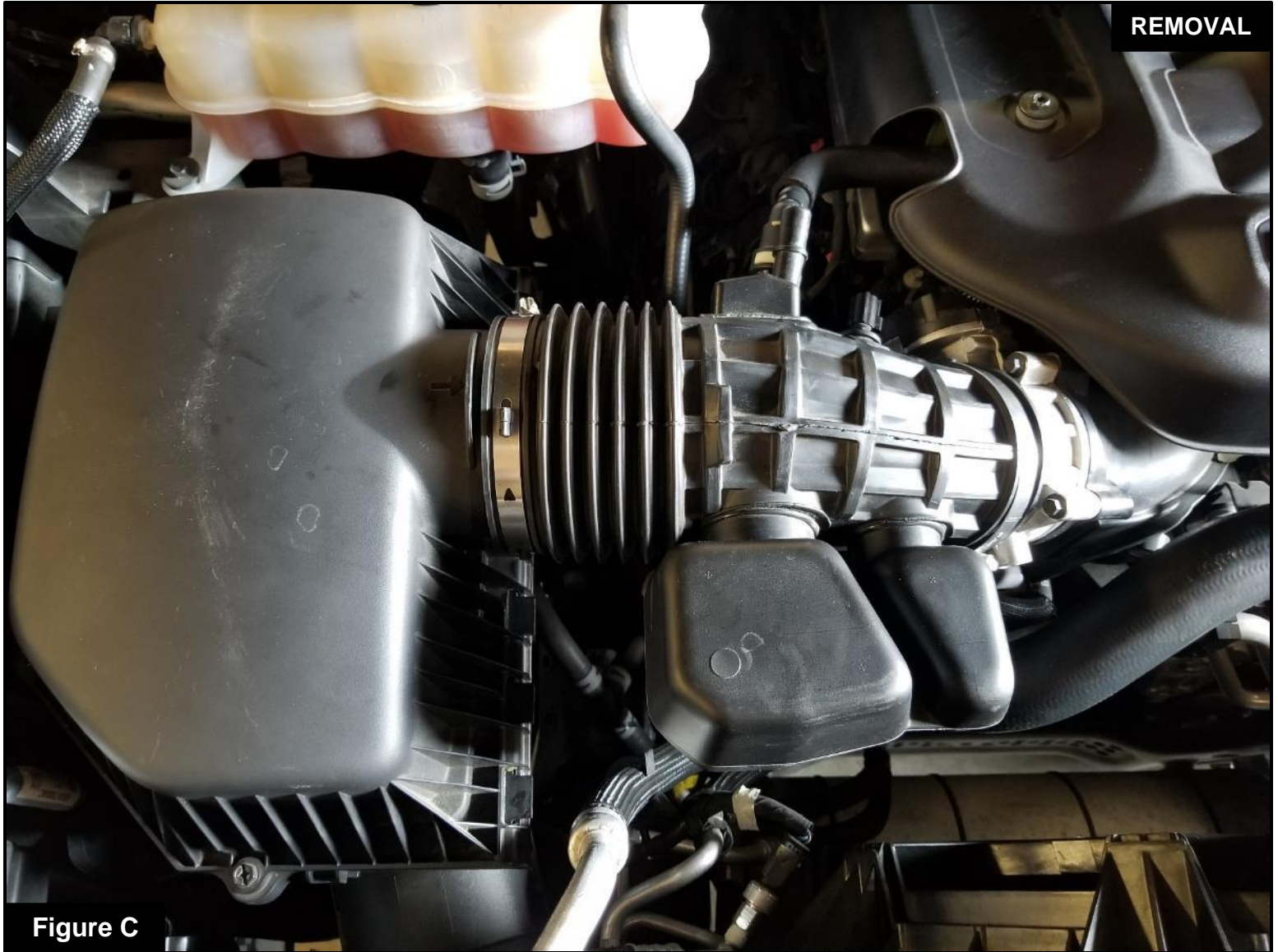

Figure B

**Refer to Figure B for Step 3**

Step 3: Loosen the clamp on the throttle body side.



REMOVAL

Figure C

**Refer to Figure C for Step 4**

Step 4: Carefully lift the factory housing to remove both the factory tube and housing from the engine bay.

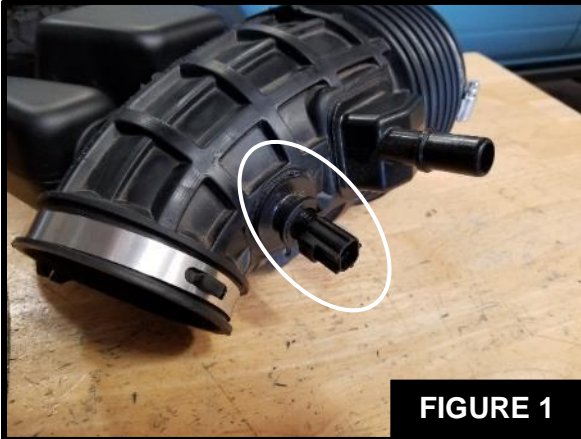

**Figure D**

### **Refer to Figure D for Steps 5-7**

Step 5: Install the supplied rubber grommet and air temperature fitting into the aFe POWER intake tube.

**NOTE: It may help to use lubricant to slip the temperature fitting into the grommet.**

Step 6: Transfer the temperature sensor from the factory intake tube to the aFe POWER intake tube.

Carefully rotate the sensor counterclockwise to remove it from the factory intake tube. Then, install the sensor into the aFe POWER intake tube by pushing it into the fitting and rotating clockwise by a quarter-turn to keep it from sliding out.

**NOTE: Keep the factory O-ring installed on the temperature sensor to provide an air-tight seal.**

Step 7: Install the supplied NPT fitting into the aFe POWER intake tube.

**NOTE: This is an NPT fitting. The small gap between the tube and hex is normal.**

**Figure E****Refer to Figure E for Steps 8-9**

Step 8: Install the supplied air filter into the aFe POWER housing. Firmly press the air filter into the large opening on the side, making sure all the air filter tabs lock into place.

Step 9: Place the clamp over the flange of the air filter. Do not tighten the clamp at this time.





Figure F

**Refer to Figure F for Step 10**

Step 10: Transfer the four factory grommets from the factory housing to the aFe POWER housing.

**Figure G****Refer to Figure G for Step 11**

Step 11: This kit includes an optional plug to close off the auxiliary air inlet. Install the plug if you wish to close it off to only capture cold air from the factory inlet.

Without the plug installed, the aFe POWER intake will capture the maximum amount of air available. More airflow offers more power. Some of this air is picked up from inside the engine compartment and could be warmer air, which will affect the performance of the vehicle.

With the plug installed on the housing, it will block off any hot engine air entering the housing to make sure only the coolest air available is directed into the engine. The plug will also reduce the noise of the intake.





**Figure H**

**Refer to Figure H for Step 12**

Step 12: Install the aFe POWER housing into the vehicle by lining it up to the four factory mounts, then firmly pushing down on them.





**Figure I**

**Refer to Figure I for Steps 13-16**

Step 13: Place the clamps onto the supplied coupling, but do not tighten at this time. Install the smaller end of the coupling over the throttle body.

Step 14: First, slide the aFe POWER tube into the air filter opening, and then onto the coupling. Align the filter, tube and coupling, then tighten all clamps.

Step 15: Reconnect the temperature sensor harness to the temperature sensor.

Step 16: Reconnect the crankcase breather line to the quick-disconnect fitting on the aFe POWER intake tube.



Figure J

**Refer to Figure J for Step 17**

Step 17: Make sure all components and connections are secure. Your installation is now complete. Thank you for choosing aFe POWER!

**NOTE: Check all bolts, clamps, and connectors after 100-200 miles.**



**Page left blank intentionally.**





**Page left blank intentionally.**



***advanced FLOW engineering, inc.***

Corona, CA 92879

<https://afepower.com/contact>