

advanced FLOW engineering

Cold Air Intake System

Instruction Manual P/N: 56-70056D / 56-70056R

Make: **Toyota**
Make: **Subaru**

Model: **GR86**
Model: **BRZ**

Year: **2022-2023**
Year: **2022-2023**

Engine: **H4-2.4L**
Engine: **H4-2.4L**



- Please read the entire instruction manual before proceeding.
- Ensure all components listed are present.
- For technical support please call at 951-493-7185.
- Ensure you have all necessary tools before proceeding.
- Do not attempt to work on your vehicle when the engine is hot.
- Retain factory parts for future use.

Label	Qty.	Description	Part Number
A	1	Air Filter (Pro DRY S) for 56-70056D	21-91103
A	1	Air Filter (Pro 5R) for 56-70056R	24-91103
B	1	Tube	05-5670056B1
C	1	Housing	05-5670056B2
D	1	Coupling, Silicone	05-01416
E	2	Clamp, #052	03-50008
F	2	Screw, M4	03-50490
G	1	Fitting, Aluminum: 1/8-NPT	03-50615
H	1	Plug, Takeda	05-01527

Installation will require the following tools:

Socket set, socket wrench, T20 torx bit, screwdriver, pliers.

Warranty information available at <https://afepower.com/contact#warranty>.

Emissions Disclaimer:

This product is not currently CARB exempt and is not available for purchase in California or for use on any vehicle registered with the California Department of Motor Vehicles.

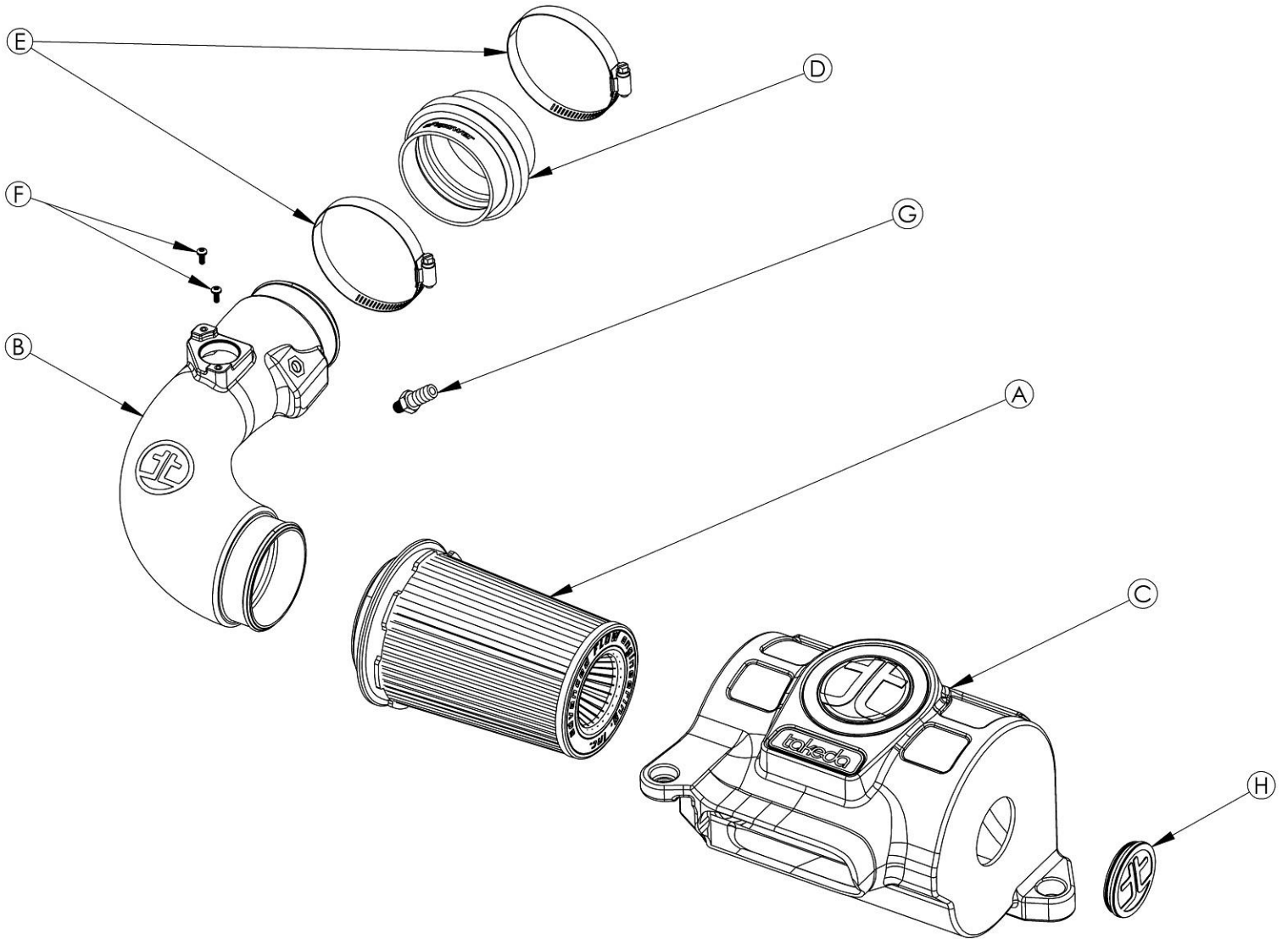



Refer to Figure A for Steps 1-3

Step 1: Disconnect the mass air flow (MAF) sensor harness and detach the harness from the factory airbox.

Step 2: Remove the crankcase (CCV) hose off the factory intake tube. Keep the pinch clamp for later use.

Step 3: Loosen the clamp on the factory intake tube on the throttle body side.



Figure B

Refer to Figure B for Steps 4-5

Step 4: Remove the three (3) bolts securing the factory housing. Keep for later use.

Step 5: Carefully lift the factory intake tube and housing out of the vehicle.

**Figure C**

Refer to Figure C for Steps 6-8

Step 6: Install the supplied air filter into the Takeda housing. Firmly press the air filter into the large opening on the side, making sure the air filter tabs lock into place.

Step 7: Place the clamp onto the flange of the air filter, but do not tighten at this time.

Step 8: Transfer two (2) of the factory grommets and sleeves from the factory housing to the Takeda housing.

**Figure D**

Refer to Figure D for Step 9

Step 9: This kit includes an optional plug to close off the auxiliary air inlet. Install the plug if you wish to close it off and to only capture air from the factory inlet.

NOTE: Without the plug installed, the Takeda intake will capture the maximum air available. More airflow offers more power. Some of this air is picked up from inside the engine compartment and could be warmer air. Warmer air will affect the performance of the vehicle.

The plug installed on the housing will block off any hot engine air entering the housing to make sure the coolest air available is directed into the engine. The plug will also reduce the noise of the intake.

**Figure E****Refer to Figure E for Steps 10-11**

Step 10: Transfer the mass air flow sensor to the Takeda intake tube and secure with the supplied screws.

Step 11: Install the supplied NPT fitting into the Takeda intake tube.

NOTE: This is an NPT fitting. Do not overtighten. The small gap between the tube and hex is normal.

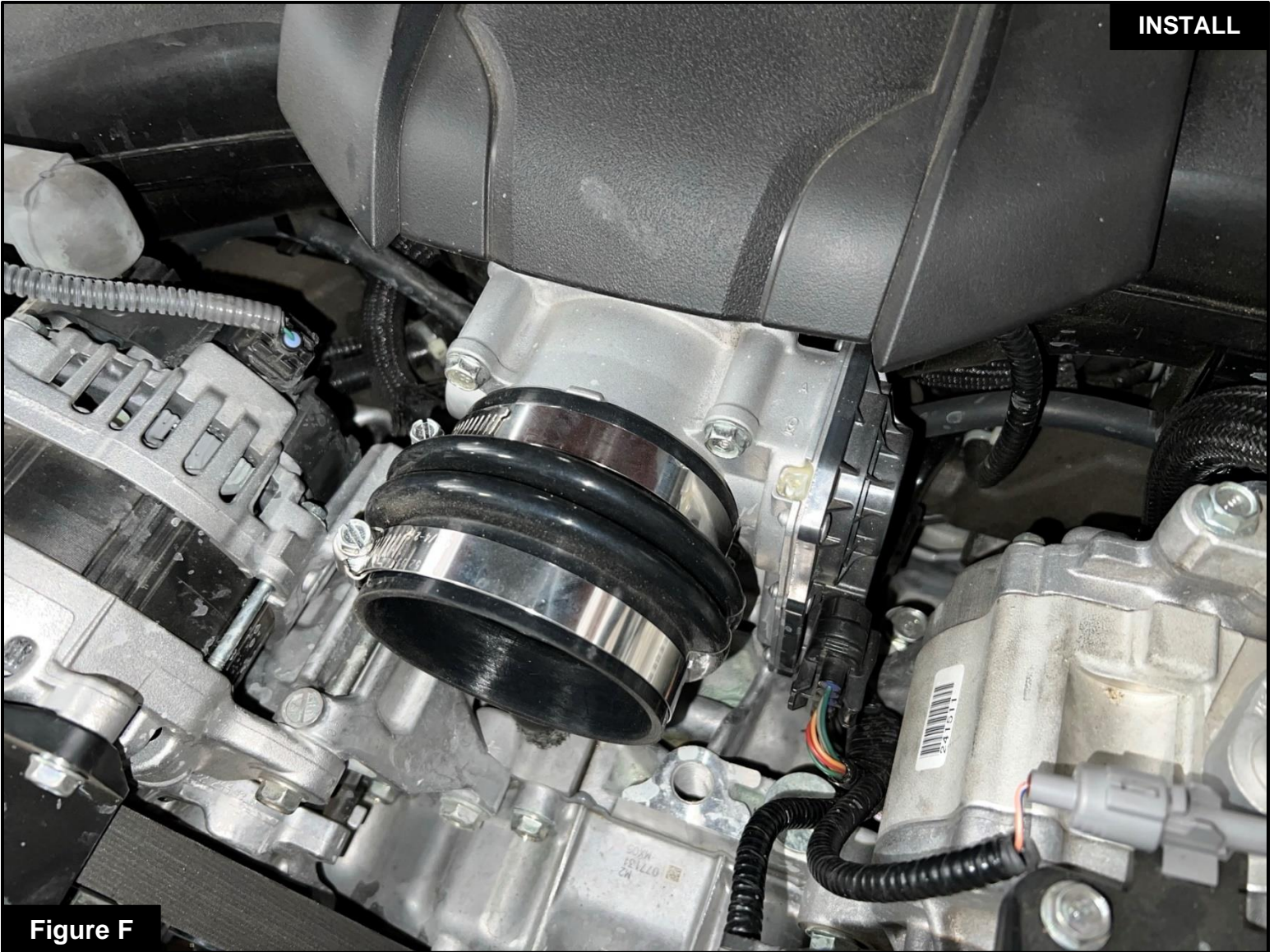
**Figure F****Refer to Figure F for Steps 12-13**

Step 12: Install the supplied coupling onto the throttle body and place the supplied clamps onto the coupling.

Step 13: Tighten the clamp between the coupling and throttle body only. Do not tighten the open end of the coupling at this time.



Figure G

Refer to Figure G for Step 14

Step 14: Install the assembled Takeda housing and air filter into the engine bay by using two (2) factory bolts from **Step 4**.



Figure H

Refer to Figure H for Steps 15-18

Step 15: Slip the Takeda intake tube into the air filter and coupling, then tighten the clamps between the Takeda intake tube, coupling, and air filter.

Step 16: Re-connect the mass air flow sensor to the sensor harness.

Step 17: Connect the factory crankcase hose to the NPT fitting and secure it with the factory pinch clamp from **Step 2**.

Step 18: Make sure all components and connections are secure. Your installation is now complete. Thank you for choosing Takeda!

NOTE: Check all bolts, clamps, and connectors after 100-200 miles.



advanced FLOW engineering, inc.

Corona, CA 92879

<https://afepower.com/contact>