

# INSTALLATION INSTRUCTIONS

**MAKE:** Hyundai  
**MODEL:** Veloster N  
**YEAR:** 2021-2022  
**ENGINE:** L4-2.0L (t)

49-37029-B  
 49-37029-P

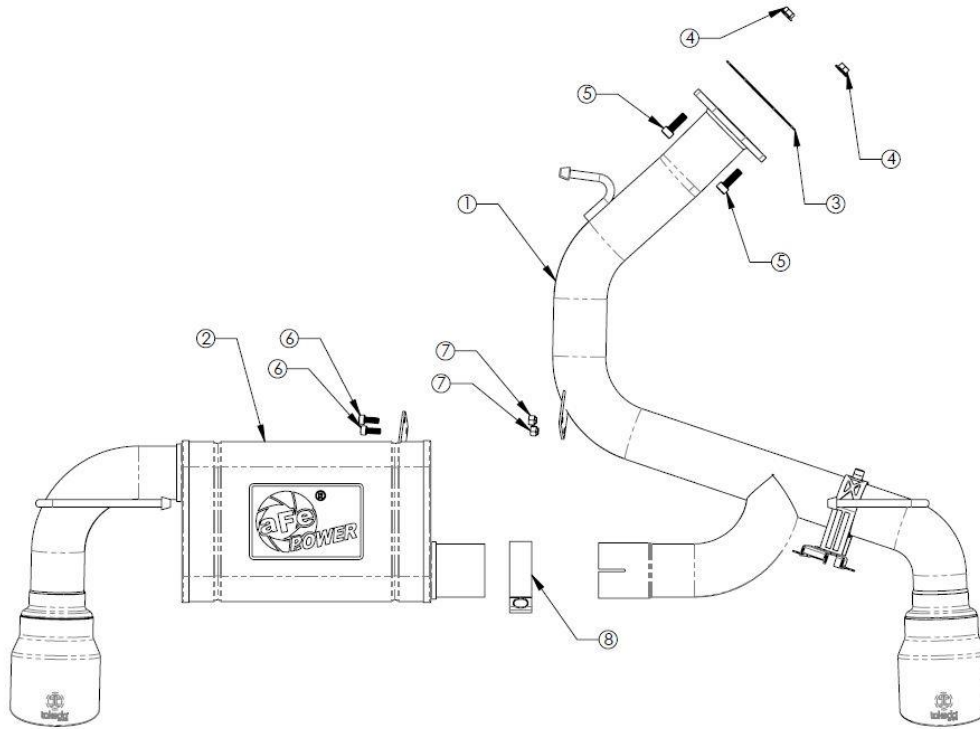

Item	Description	Part Number	Quantity
1	Tailpipe, Right, Polished Tip	05-245360	1
1	Tailpipe, Right, Black Tip	05-245360B	1
2	Muffler Assembly, Polished Tip	05-245359	1
2	Muffler Assembly, Polished Tip	05-245359B	1
3	Gasket	05-46400	2
4	Nut, M10 x 1.5	03-50189	2
5	Bolt, M10 x 1.5 x 35mm	05-50452	2
6	Socket Head Cap Screw, M8 x 1.25 x 16mm	03-50171	2
7	Nut, M8 x 1.25 Hex Lock	05-46057	2
8	Band Clamp, 3"	05-41055	1

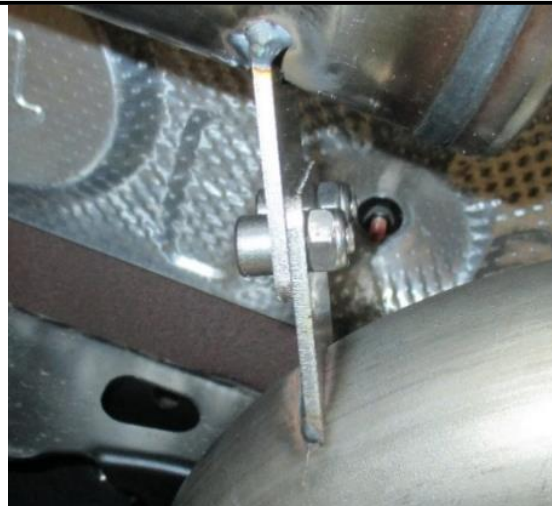



## INSTALLATION INSTRUCTIONS

**MAKE:** Hyundai  
**MODEL:** Veloster N  
**YEAR:** 2021-2022  
**ENGINE:** L4-2.0L (t)

**Cat-Back Exhaust**

49-37029-B

49-37029-P

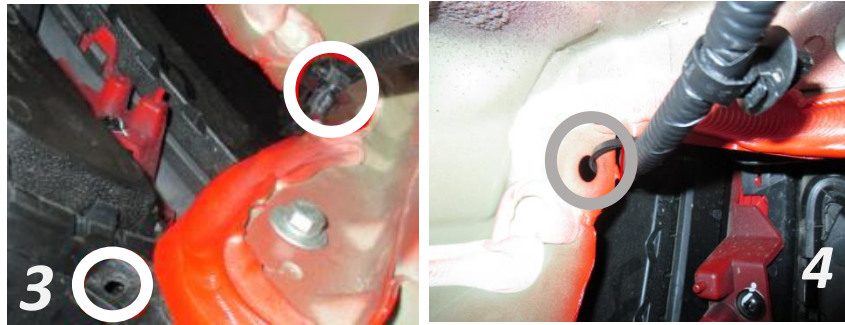

**aFe POWER recommends professional installation on this product.** Thoroughly inspect the aFe POWER exhaust system to make sure there is no damage from shipping (if damage is noted, immediately contact aFe POWER customer service). Allow time for your vehicle to cool down prior to installation. When working on your vehicle proceed with caution. Wear protective safety equipment; eye goggles and gloves to ensure a safe installation.

Install band clamps to proper torque specifications of 40-45 ft-lb.

1. **(Read instructions prior to installation.)** It is recommended to not fully tighten the exhaust until it has been fully installed. Leave loose for adjustability.
2. Secure vehicle on jack stands (refer to your manual for specified jack stand positions).
3. For faster installation, spread out the parts of the exhaust alongside your vehicle as shown in the diagram above.
4. Secure the stock exhaust with jack/stands.
5. Loosen the (x2) nuts securing the muffler assembly to the OE mid-pipe.
6. Unplug the valve motor connector and put to the side as not to damage the connector.
7. Remove the (x3) isolation mounts on the muffler assembly using hanger pliers or a pry bar and remove the OE muffler assembly.
8. Assemble the Takeda Muffler Assembly and Takeda Tail-pipe outside of the vehicle using the supplied 3" band clamp, and (x2) M8 nuts and (x2) M8 bolts. See reference image (2).
9. Remove the (x3) nuts to remove the OE valve motor off the OE muffler assembly.
10. Install the OE valve motor onto the assembled Takeda Axle-Back using the supplied hardware.
11. Install the Takeda Axle-Back on to the vehicle using the supplied gaskets and hardware.
12. Remove the valve motor wire by removing the snap in plug from its mounting location. See reference image (3).
13. Using the supplied zip-tie, secure the valve wire in the circled location located on the chassis shown in reference image (4).
14. Ensure that all the components of the Takeda exhaust system are aligned and are at a safe clearance from all wires, hoses, brake lines, body parts, and tires.
15. Start from the front of the Takeda exhaust system and evenly tighten all clamps and fasteners.
16. Start the vehicle and check for any leaks. If any leaks are found, determine cause and repair as necessary.
17. Remove vehicle from jacks stands.
18. It is recommended to re-tighten all clamps and hardware after 50-100 miles.