

HD
MOMENTUM

advanced FLOW engineering

Cold Air Intake System

Instruction Manual P/N: 50-70026D/50-70026T

Make: TOYOTA Model: LAND CRUISER (J200)* Year: 2008-2021

Engine: V8-4.5L(td)

* Non-US Model



- Please read the entire instruction manual before proceeding.
- Ensure all components listed are present.
- If you are missing any of the components, call customer support at 951-493-7185.
- Ensure you have all necessary tools before proceeding.
- Do not attempt to work on your vehicle when the engine is hot.
- Retain factory parts for future use.

Label	Qty.	Description	Part Number
A	1	Air Filter (Pro 10R) For 50-70026T	20-91208T
A	1	Air Filter (Pro DRY S) For 50-70026D	20-91208D
B	1	Tube	05-5070026B1
C	1	Housing	05-5070026B2
D	2	Clamp, 064 (3-9/16" - 4-1/2 ")	03-50006
E	1	Coupling, Silicone	05-01721
F	2	Screw, Torx: M4 x 10mm	03-50490
G	1	Plug, Silicone	05-01429

Installation will require the following tools:

8mm, 10mm and 11mm Nut Drivers or Ratchet and Sockets, Flat Head and Phillips Screwdriver, T20 Torx Driver.

Warranty Information available at: <https://afepower.com/contact#warranty>

Emissions Disclaimer: This product does not require a CARB EO# (Vehicle is not sold in the U.S.)

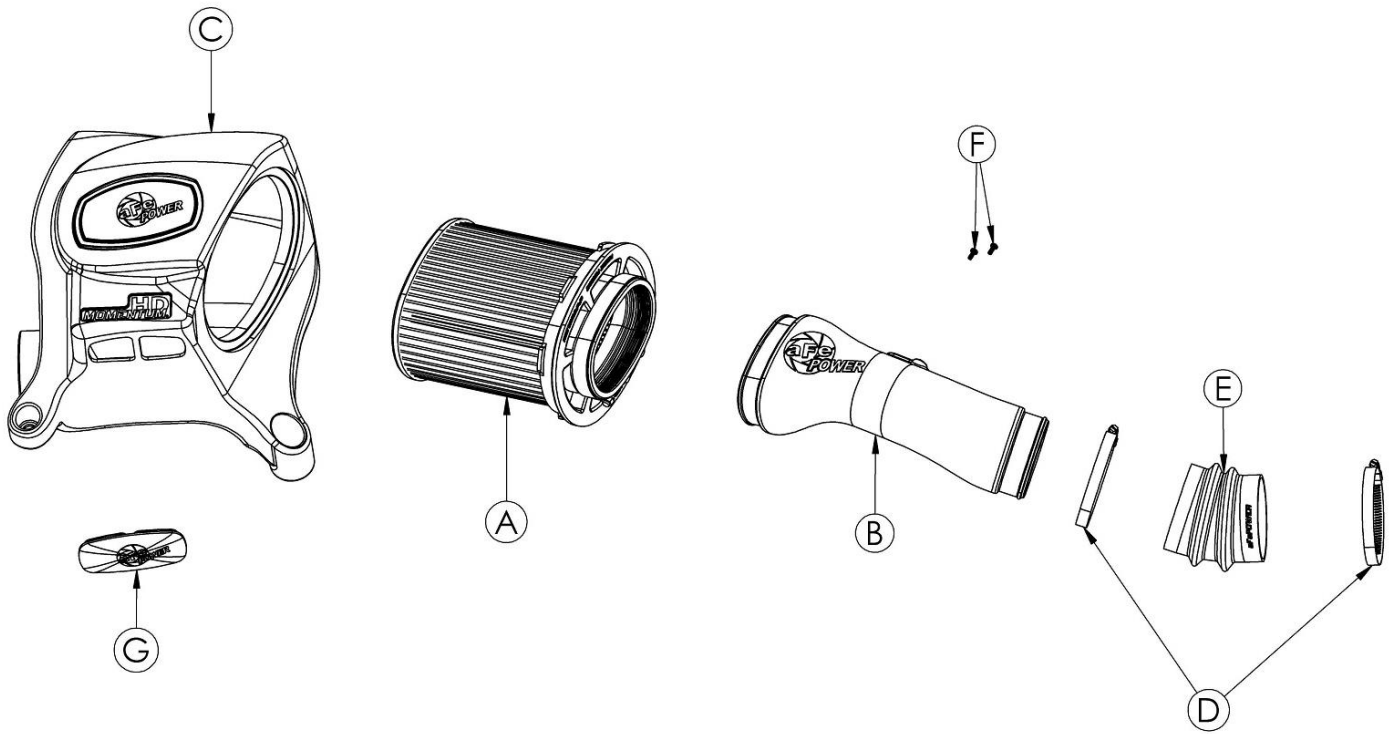



Figure A

Refer to Figure A for Steps 1-2

Step 1: Disconnect the Mass Air Flow (MAF) sensor and unclip the harness from the airbox.

Step 2: Using a 10mm socket or nut driver, loosen the clamp securing the intake tube to the turbo inlet.



Refer to Figure B for Step 3

Step 3: Remove the three (3) bolts holding the housing then lift the full assembly to remove from vehicle.



Refer to Figure C for Step 4

Step 4: Keep the air inlet trim installed on the vehicle.

**Figure D****Refer to Figure D for Step 5**

Step 5: Transfer the factory Mass Air Flow (MAF) from the factory tube to the aFe POWER tube and secure it with the provided M4 screws.

**Figure E****Refer to Figure E for Step 6**

Step 6: Install the air filter by firmly pushing it into the housing until the filter tabs lock into place. Install the clamp onto the filter but do not tighten it at this time.



Figure F

Refer to Figure F for Step 7

Step 7: Transfer the three (3) grommets from the bottom of the factory air box to the aFe POWER housing.

**Figure G****Refer to Figure G for Step 8**

Step 8: The kit includes an optional plug to close off the auxiliary air inlet. Install the plug if you wish to close off the auxiliary air inlet to only capture cold air from the fender.

- Without the plug installed, the aFe POWER intake will capture the maximum amount of air available. More airflow offers more power, yet some of the air picked up from inside the engine compartment could be warmer air. The warmer air will affect the performance of the vehicle.
- The plug installed on the housing will block off any hot engine air entering the housing to make sure that the coolest air available is directed into the engine. Intake noise will also be reduced if using the plug.

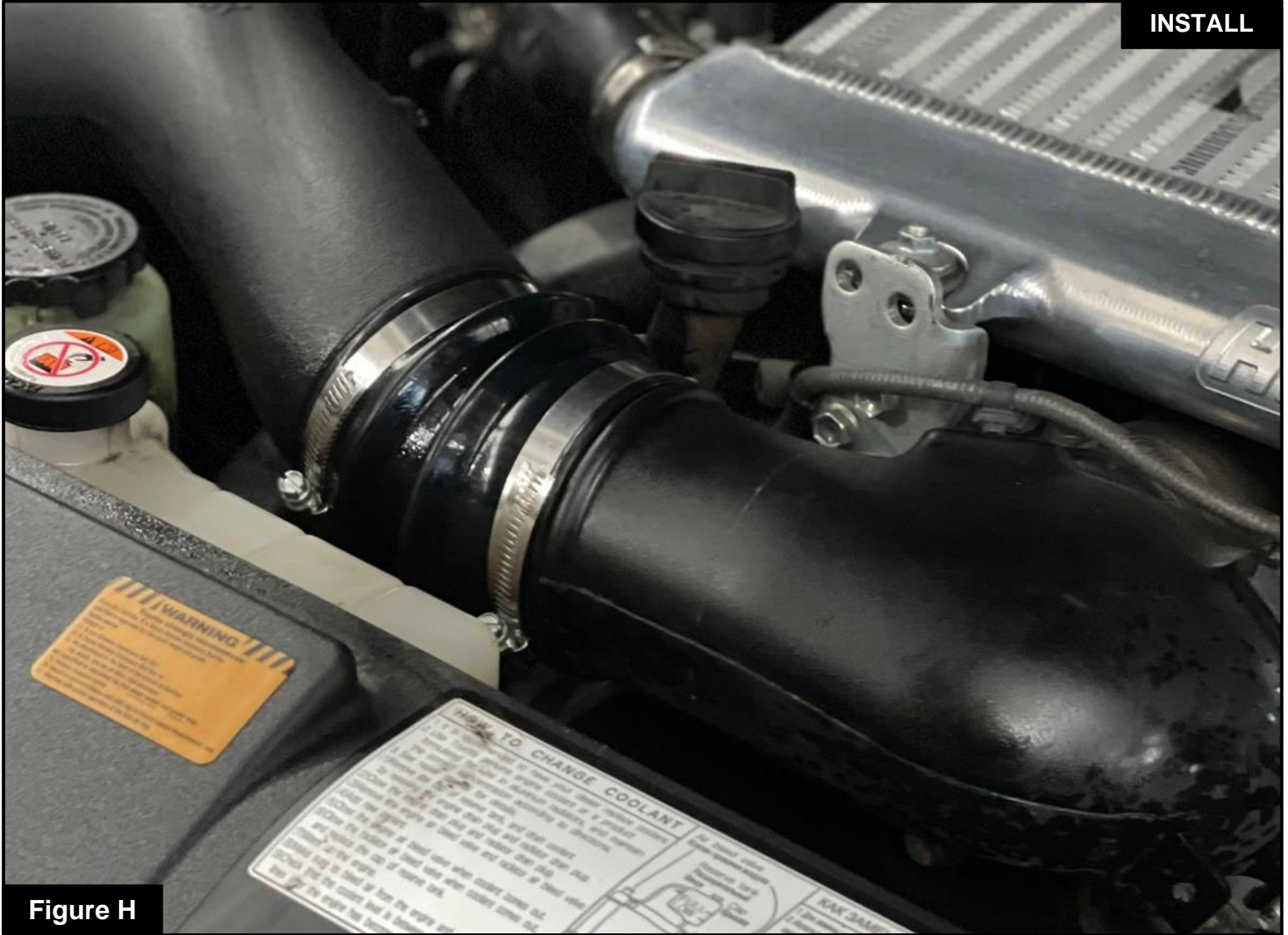
**Figure H****Refer to Figure H for Step 9**

Step 9: Install the supplied coupling onto the turbo inlet with the supplied clamps. Tighten only the turbo inlet side at this time.



Figure I

Refer to Figure I for Step 10

Step 10: Install the aFe POWER air box into the vehicle by lining the housing on the three factory mounting positions. Then secure it using the bolts removed in Step 3.



Figure J

Refer to Figure J for Steps 11-13

Step 11: Install the aFe POWER intake tube between the coupling and filter. Align the tube and coupling, then tighten all clamps.

Step 12: Reconnect the MAF sensor harness to the MAF sensor.

Step 13: Make sure all clamps and connections are secured. Your installation is now complete. Thank you for choosing aFe POWER!



PAGE LEFT BLANK INTENTIONALLY



PAGE LEFT BLANK INTENTIONALLY



advanced FLOW engineering, Inc.

Corona, CA 92879

<https://afepower.com/contact>