

***advanced FLOW engineering***

Takeda Stage-2 Cold Air Intake System

**Instruction Manual** P/N: 56-70044D / 56-70044R

Make: Mazda

Model: 3

Year: 2019-2023

Engine: L4-2.5L



- Please read the entire instruction manual before proceeding.
- Ensure all components listed are present.
- If you are missing any of the components, call customer support at 951-493-7100.
- Ensure you have all necessary tools before proceeding.
- Do not attempt to work on your vehicle when the engine is hot.
- Disconnect the negative battery terminal before proceeding.
- Retain factory parts for future use.

Label	Qty.	Description	Part Number
A1	1	Air Filter (Pro 5R)	R24-91103
A2	1	Air Filter (Pro DRY S)	R21-91103
B	1	Tube	05-5610020B1
C	1	Housing	05-5670044B2
D	1	Coupling, Silicone Bellow: 2.75" ID x 3.25"L	05-01500
E	2	Clamp, 044 (2-5/16" - 3-1/4")	03-50019
F	1	Plug, Silicone	05-01527
G	2	Screw, Torx M4	03-50491

**Installation will require the following tools:**

T-20 Torx driver, #2 Phillips screwdriver, 8mm nut driver, and 10mm nut driver.

Warranty Information available at <https://afepower.com/contact#warranty>

**Emissions Disclaimer:** This product is not currently CARB exempt and is not available for purchase in California or for use on any vehicle registered with the California Department of Motor Vehicles.

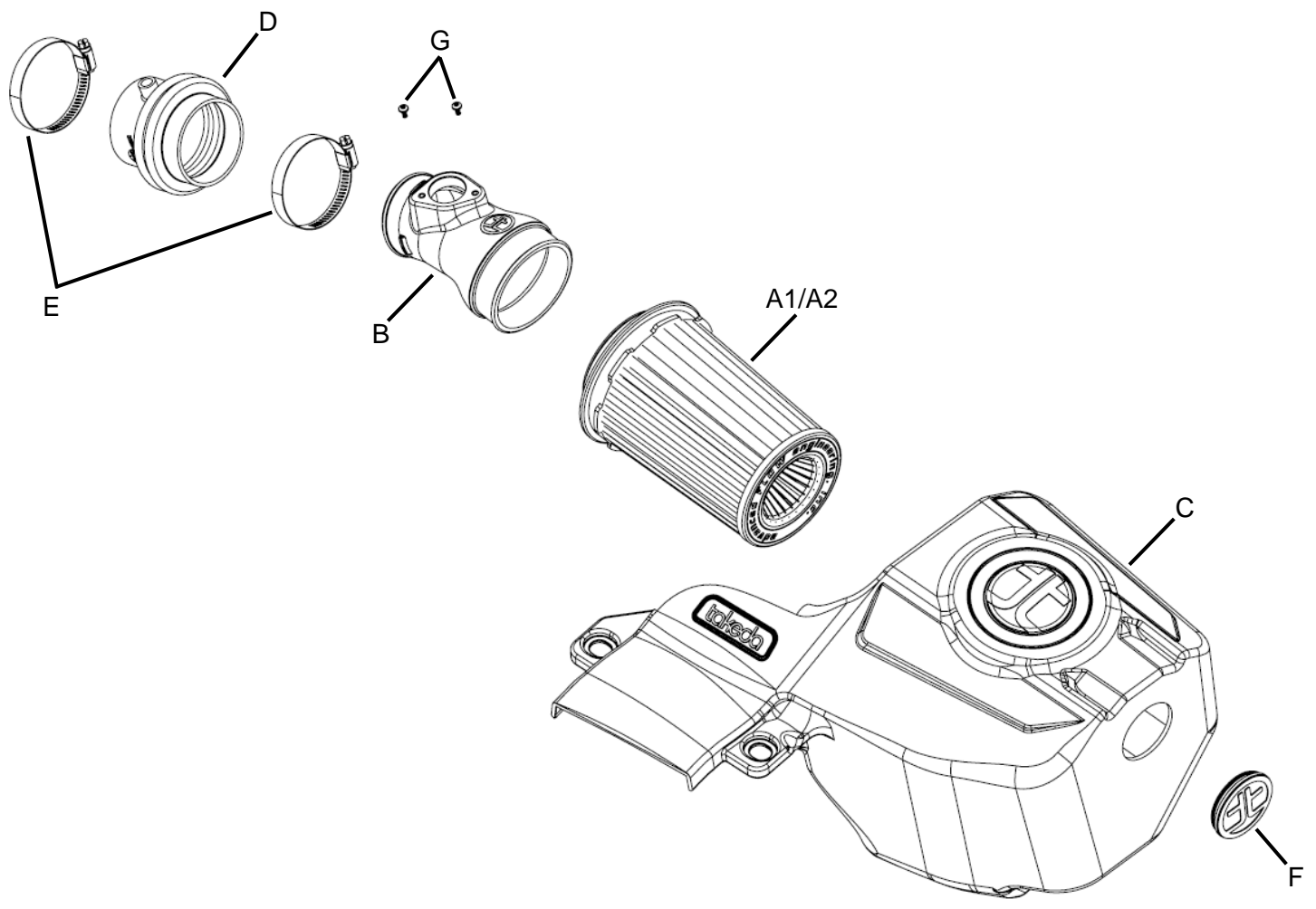

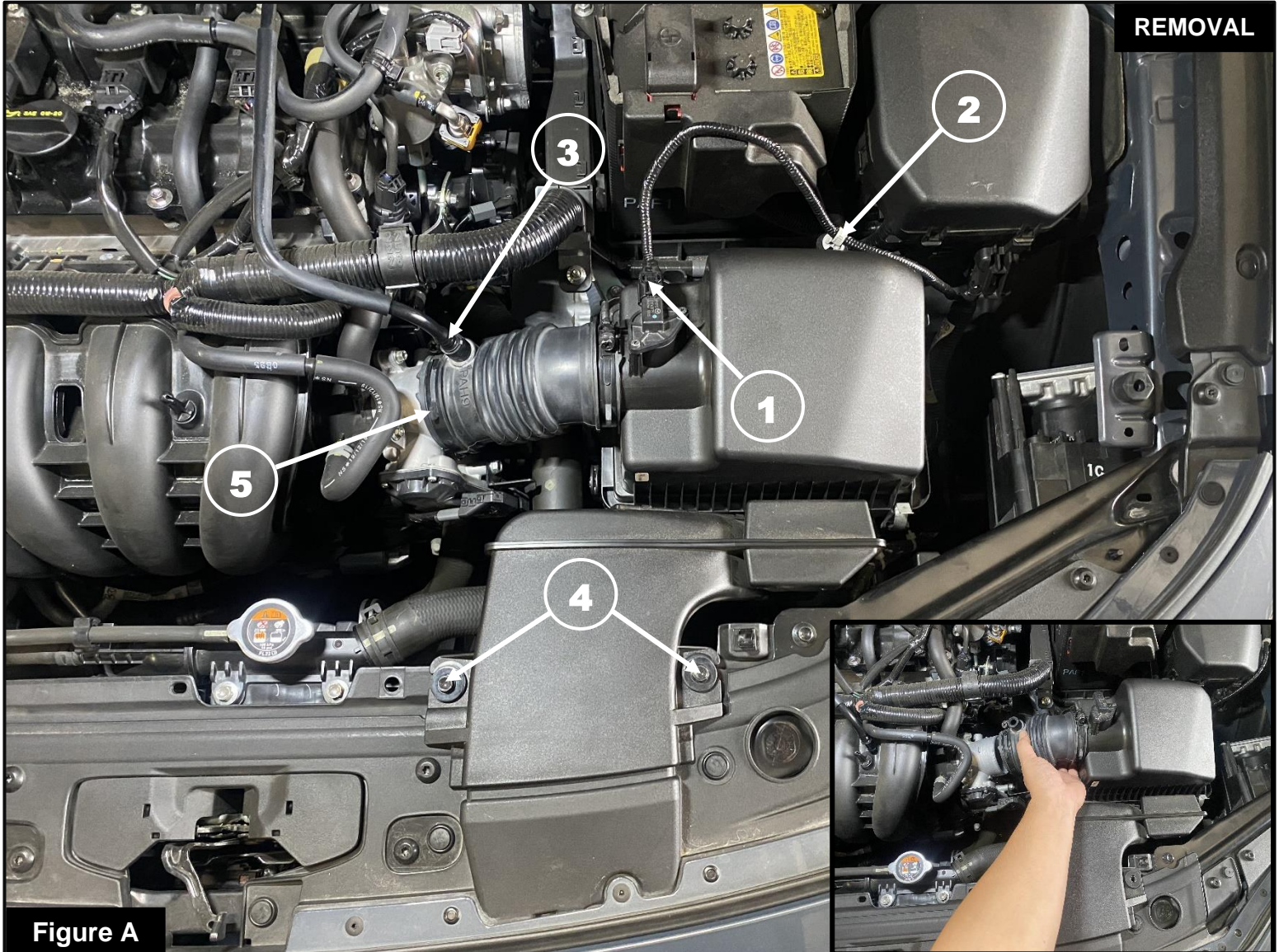

REMOVAL

Figure A

**Refer to Figure A for Step 1-6**

- Step 1: Remove engine cover by lifting and releasing from the 4 mounting grommets.
- Step 2: Disconnect the Mass Air Flow (MAF) harness ① from MAF sensor.
- Step 3: Remove the MAF harness clip ② from the airbox.
- Step 4: Remove the PCV hose ③ from the intake tube by pulling it up gently
- Step 5: Using a 10mm nut driver, remove the screws ④ holding down the inlet scoop. These will be used for the installation of the Takeda Intake System.
- Step 6: Using a 10mm nut driver, loosen the clamp ⑤ securing the tube to the throttle body and remove the airbox from the vehicle.

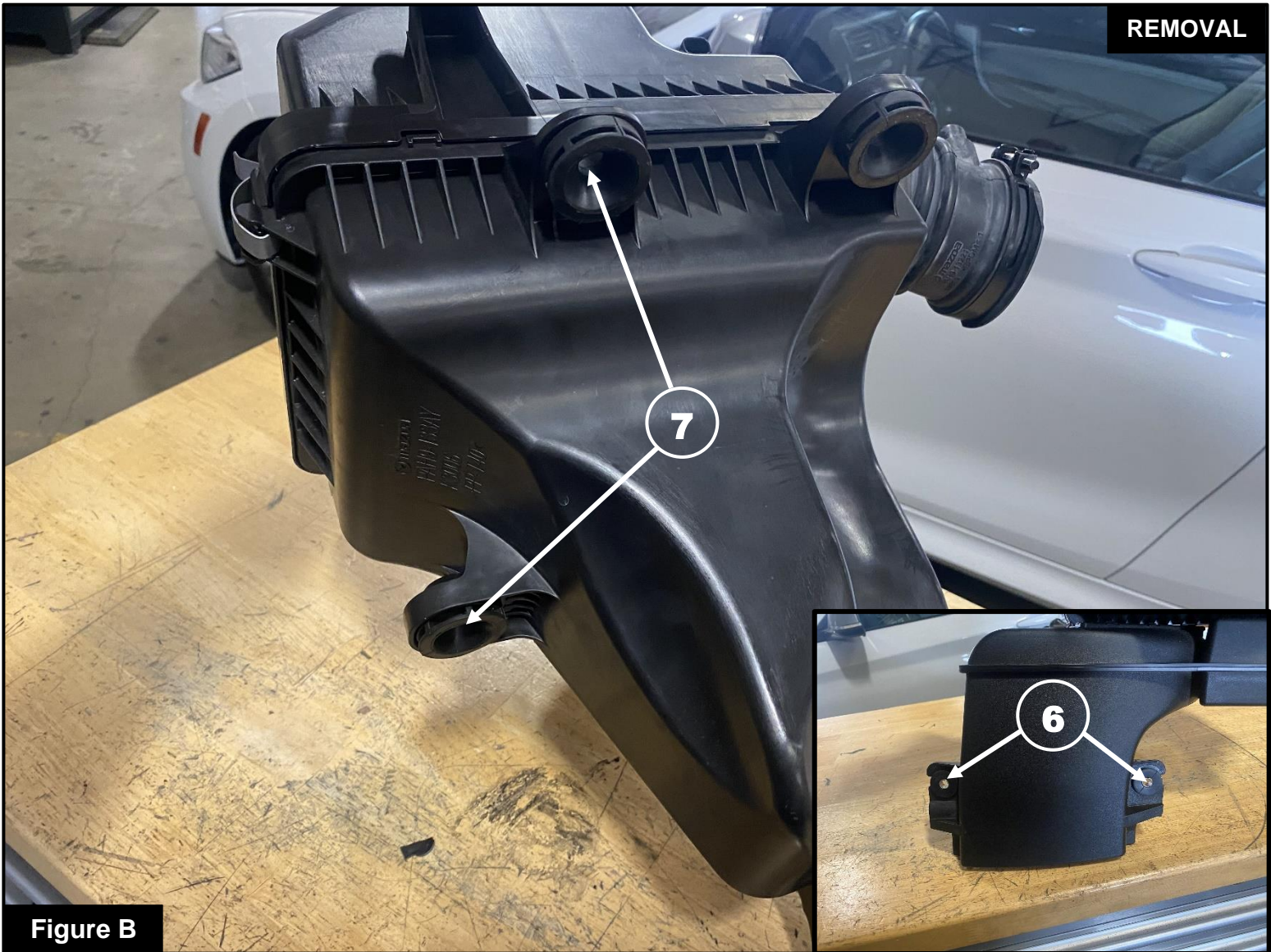

Figure B

**Refer to Figure B for Step 7-8**

Step 7: Remove the rubber grommets and steel sleeves (6) from the airbox.

Step 8: Remove the rubber grommets (7) from the airbox.

**Figure C****Refer to Figure C for Step 9-11**

Step 9: Install the rubber grommets and steel sleeves (8) removed in step 7 onto the Takeda housing.

Step 10: Install the rubber grommets (9) removed in step 8 onto the Takeda housing.

Step 11: Install the aFe POWER filter and clamp into the Takeda housing.

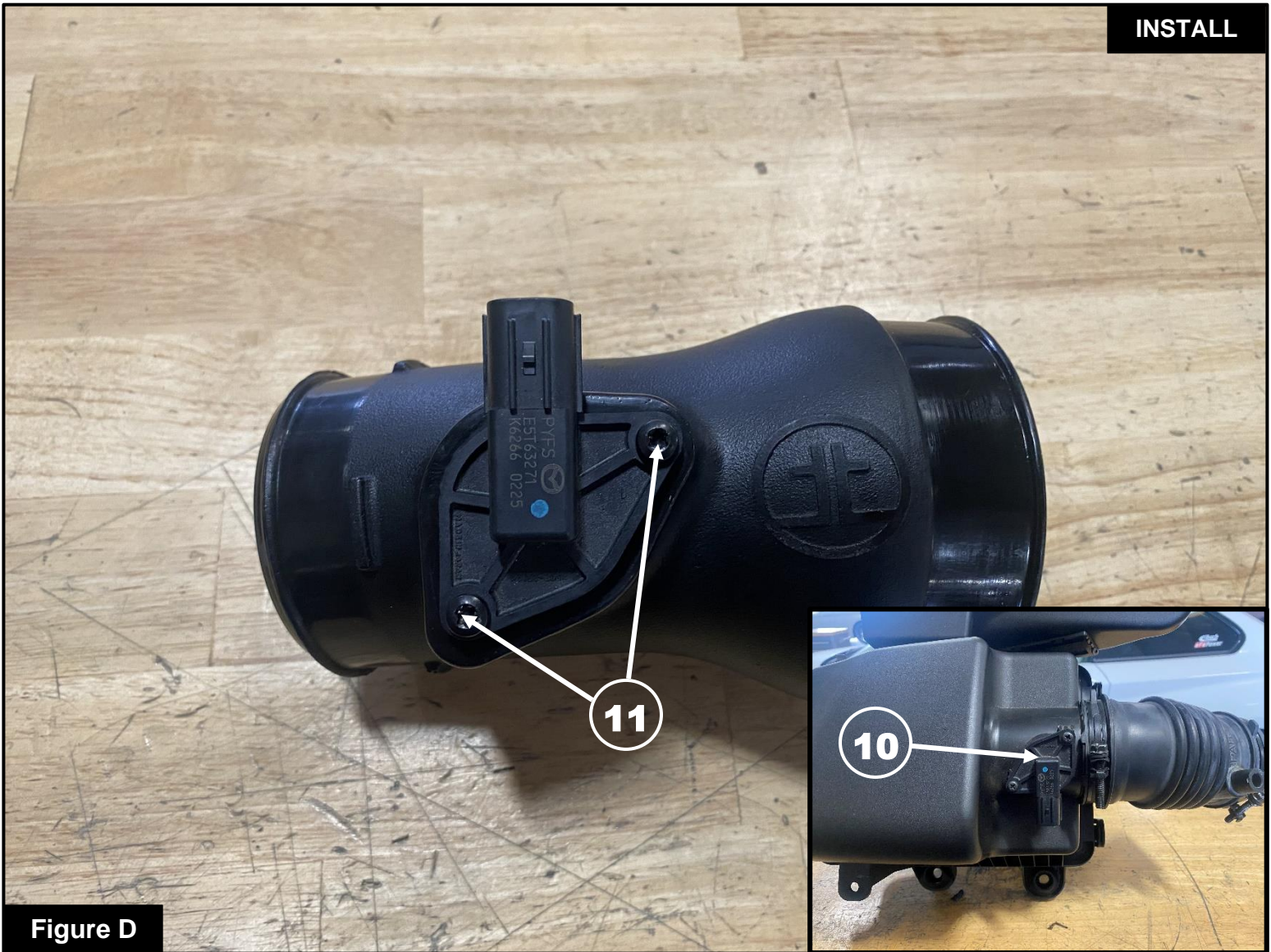
**Figure D****Refer to Figure D for Step 12-13**

Step 12: Using a #2 Phillips screwdriver, remove the MAF sensor ⑩ from the airbox.

Step 13: Using a T20 Torx driver, install the MAF sensor into the Takeda intake tube using the provided M4 hardware ⑪.

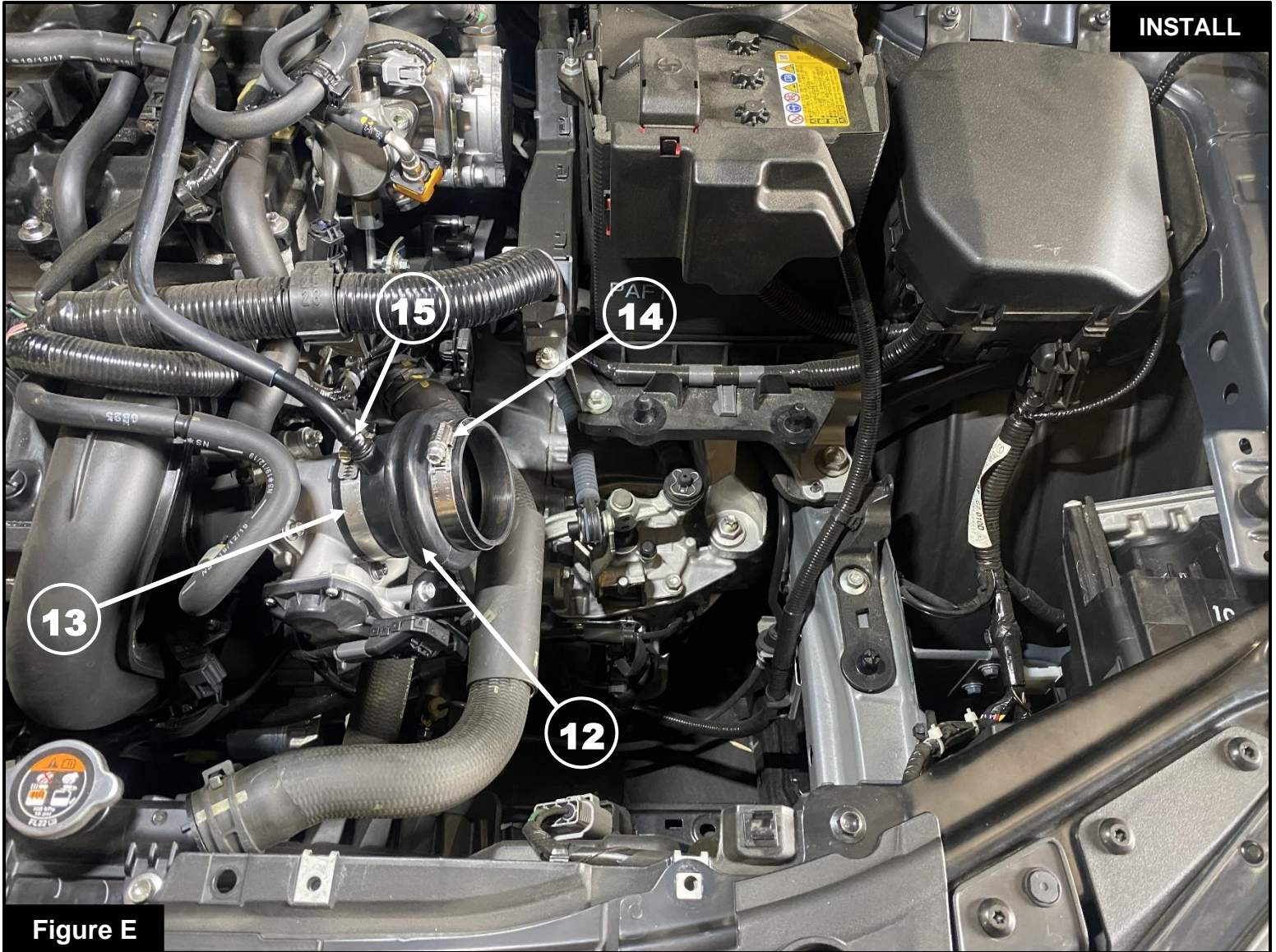
**Figure E**

### **Refer to Figure E for Steps 14-16**

Step 14: Install the bellows coupling (12) onto the throttle body using the provided (#044) hose clamp (13) and tighten.

Step 15: Install a (#044) hose clamp (14) onto the open end of the coupling but do not tighten.

Step 16: Re-insert the PCV hose (15) (removed in step 4) into the coupling.



**Figure F****Refer to Figure F for Step 17**

Step 17: Insert the Takeda housing in to the vehicle, making sure that the rubber grommets snap into place, and re-install the screws **16** removed in step 5 using a 10mm nut driver.



**Figure G**

**Refer to Figure G for Steps 18-20**

Step 18: Install the Takeda intake tube, starting at the bellows coupling (17) and then rotating the tube downward to insert into the air filter (18). Make sure the intake tube is properly aligned with the coupler and air filter.

Step 19: Tighten the clamp at the bellows coupling (17) and at the air filter (18).

Step 20: Reconnect the MAF harness plug (19) removed in step 2.

**Figure H****Refer to Figure H for Step 21**

Step 21: Reinstall engine cover.

Your installation is now complete. Thank you for choosing Takeda.

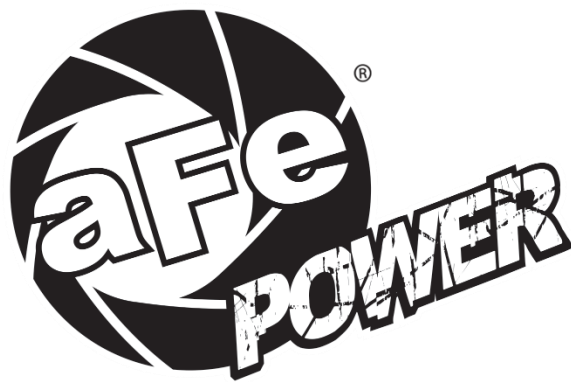

***advanced FLOW engineering, inc.***

252 Granite Street Corona, CA 92879  
TEL: 951.493.7100 • TECH: 951.493.7134  
E-Mail: Tech@aFepower.com