



INSTALLATION INSTRUCTIONS

Cat-Back Exhaust

MAKE: Porsche
MODEL: GT4 (718)
YEAR: 2020-2023
ENGINE: H6-4.0L

49-36443-B/C/P

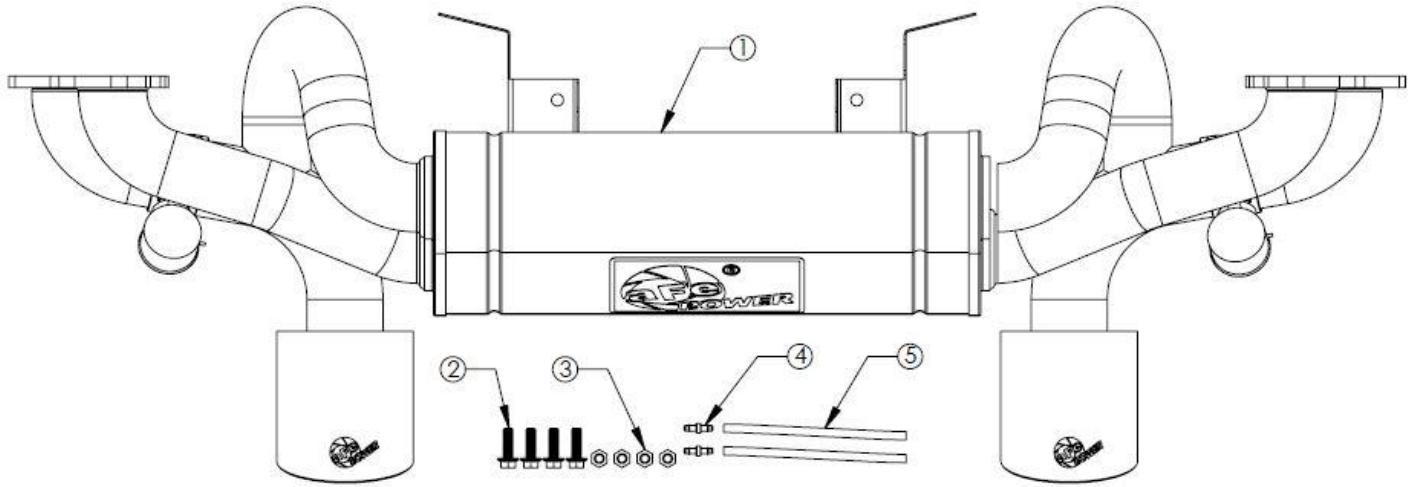

Item	Description	Part Number	Quantity
1	Exhaust System, Black Tips	05-245261B	1
1	Exhaust System, Carbon Tips	05-245261C	1
1	Exhaust System, Polished Tips	05-245261P	1
2	Bolt, M8x1.25 x 25mm	03-50421	4
3	Nut, M8x1.25	05-46057	4
4	Barbed Fitting	05-46515	2
5	Silicone Hose 4mm x 6" Long	05-46512	2

aFe POWER recommends professional installation on this product. Thoroughly inspect the aFe POWER exhaust system to make sure there is no damage from shipping (if damage is noted, immediately contact aFe POWER customer service). Allow time for your vehicle to cool down prior to installation. When working on your vehicle proceed with caution. Wear protective safety equipment; eye goggles and gloves to ensure a safe installation.

Install band clamps to proper torque specifications of 40-45 ft-lb.

Install V-band clamps with anti-seize lubricant and hand tighten only to torque specifications of 10-15 ft-lb.



INSTALLATION INSTRUCTIONS

Cat-Back Exhaust

MAKE: Porsche
MODEL: GT4 (718)
YEAR: 2020-2022
ENGINE: H6-4.0L

49-36443-B/C/P

1. **(Read instructions prior to installation.)** It is recommended to not fully tighten the exhaust until it has been fully installed. Leave loose for adjustability.
2. Secure vehicle on jack stands (refer to your manual for specified jack stand positions).
3. For faster installation, spread out the parts of the exhaust alongside your vehicle as shown in the diagram above.
4. Secure the stock exhaust with jack/stands.
5. Remove the four bolts securing the center diffuser and remove it from the vehicle.
6. Disconnect the two vacuum tubes running to the exhaust valve actuators.
7. Remove the four bolts and bolts securing the muffler to the vehicle at the center.
8. Remove the ten nuts securing the exhaust to the vehicle.
9. Remove the exhaust from the vehicle.
10. Visually inspect the OE exhaust gaskets. Replace or Re-use as necessary.
11. Transfer the center bracket from the OE muffler onto the aFe POWER exhaust using the supplied hardware.
Torque hardware to 16 Ft-Lb
12. Slide the aFe POWER exhaust over the studs on the OE link pipes and install the 10 nuts. Tighten to 16 Ft-Lb.
13. Tighten the four center bolts and nuts and torque to 16 Ft-Lb.
14. Install the supplied Vacuum tube couplings and hose between the OE vacuum tubing and the aFe POWER valves.
15. Install the center part of the diffuser.
16. Ensure that all the components of the aFe POWER exhaust system are aligned and are at a safe clearance from all wires, hoses, brake lines, body parts, and tires.
17. Start from the front of the aFe exhaust system and evenly tighten all clamps and fasteners.
18. Start the vehicle and check for any leaks. If any leaks are found, determine cause and repair as necessary.
19. Remove vehicle from jacks stands.
20. It is recommended to re-tighten all clamps and hardware after 50-100 miles.