

advanced FLOW engineering

Magnum Force Stage-2 Cold Air Intake System

Instruction Manual P/N: 54-13046D / 54-13046R

Make: RAM

Model: 2500

Year: 2019-2023

Engine: L6-6.7L(td) Cummins

Make: RAM

Model: 3500

Year: 2019-2023

Engine: L6-6.7L(td) Cummins



- Please read the entire instruction manual before proceeding.
- Ensure all components listed are present.
- If you are missing any of the components, call customer support at 951-493-7185.
- Ensure you have all necessary tools before proceeding.
- Do not attempt to work on your vehicle when the engine is hot.
- Retain factory parts for future use.

Label	Qty.	Description	Part Number
A1	1	Air Filter (Pro 5R) For 54-13046R	24-91120
A2	1	Air Filter (Pro DRY S) For 54-13046D	21-91120
B	1	Tube	05-5413046B1
C	1	Housing	05-5413046B2
D	1	Coupling, Silicone Bellow Reducer	05-01521
E	1	Clamp, #064	03-50006
F	1	Clamp, #072	03-50010
G	3	Screw, Torx: M4	03-50490
H	1	Seal, Trim: Double bulb (37.25" Length)	05-01534

Installation will require the following tools:

8mm & 10mm nut drivers or ratchet and sockets, T20 torx bit or driver, pliers or flat-head screwdriver

Warranty Information available at: <https://afepower.com/contact#warranty>

Emissions Disclaimer: This product is not currently CARB exempt and is not available for purchase in California or for use on any vehicle registered with the California Department of Motor Vehicles.

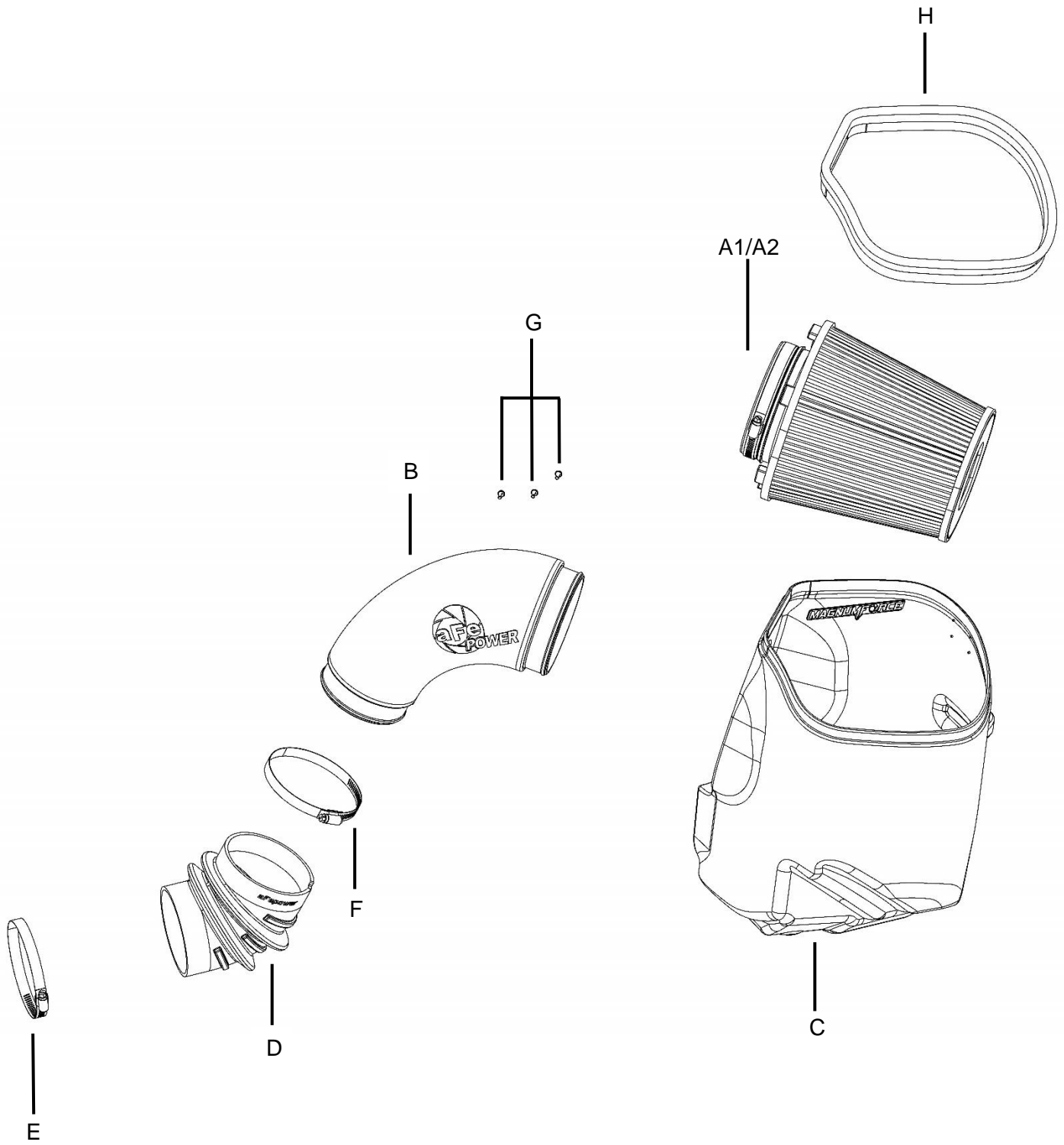

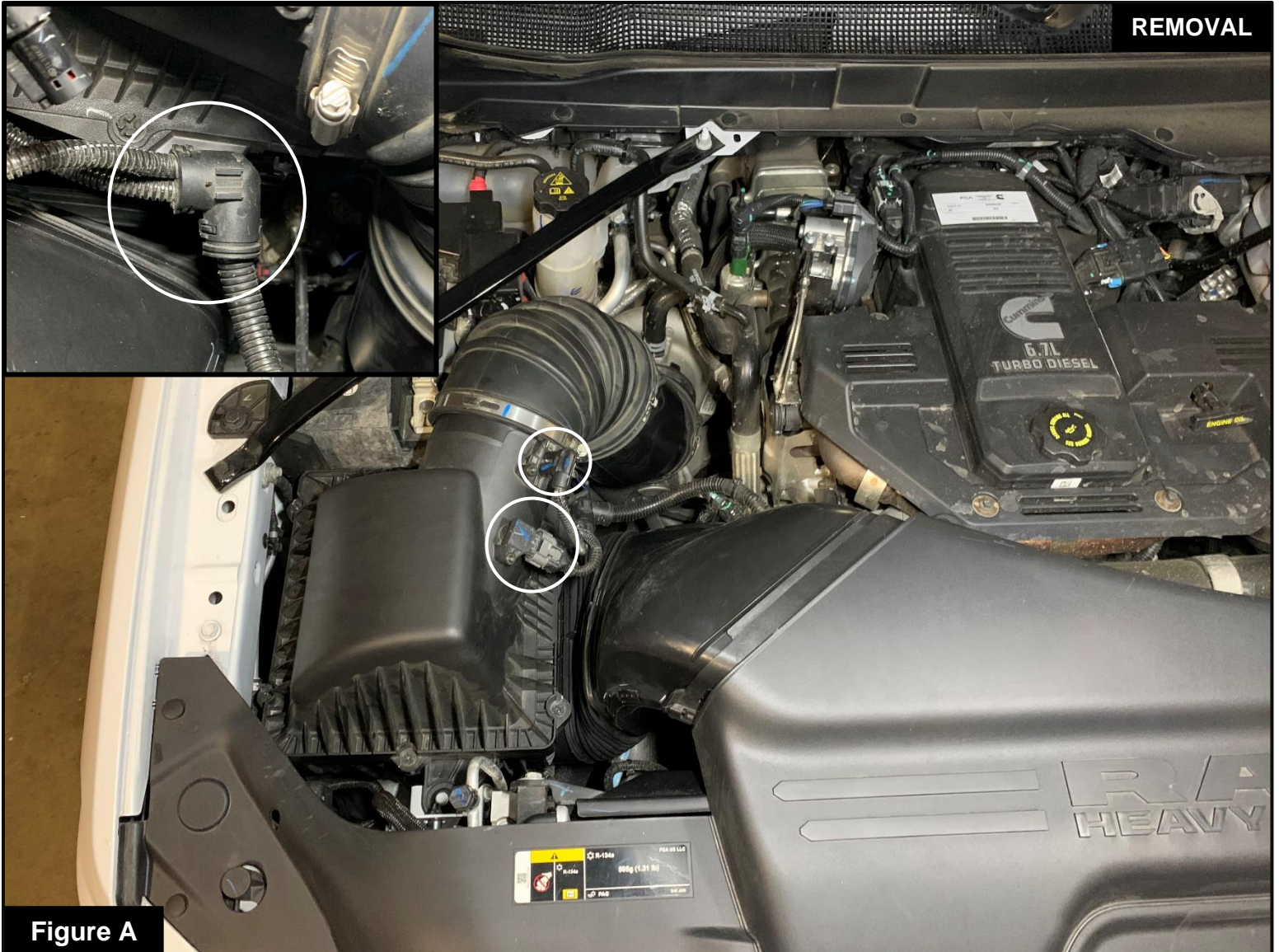
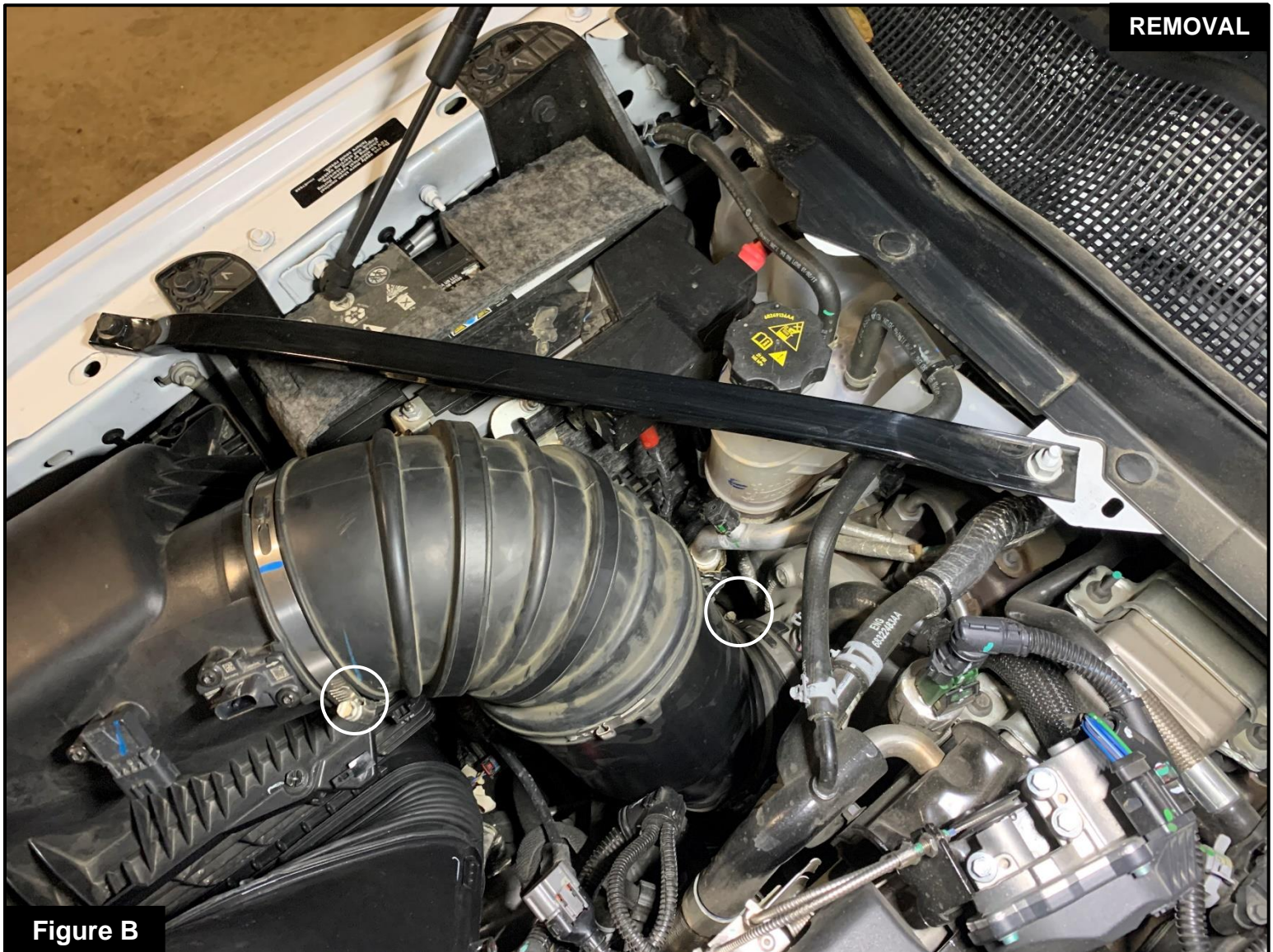

Figure A

Refer to Figure A for Steps 1-2

Step 1: After making sure your vehicle is completely off and in sleep mode, disconnect the Mass Air Flow (MAF) Sensor and temperature sensor.

Step 2: Unclip the harness from the factory air box.



Refer to Figure B for Step 3-4

Step 3: Untighten the clamps securing the factory tube to the housing and to the turbo.

Step 4: Disconnect the tube from the factory air box then from the turbo. Take the factory tube out of the vehicle.

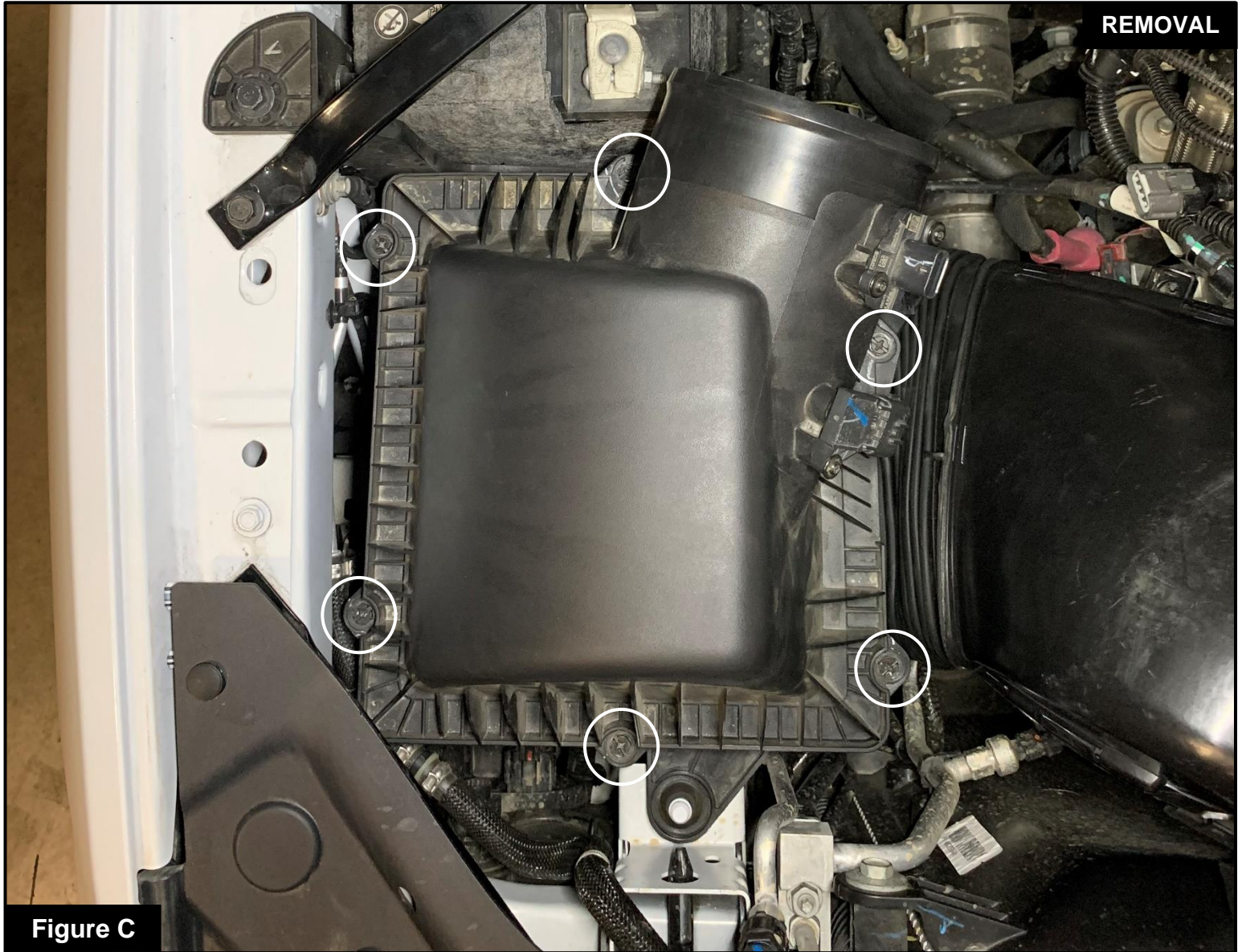

Figure C

Refer to Figure C for Steps 5-7

Step 5: Untighten the six screws securing the upper portion of the factory air box.

Step 6: Remove the upper portion of the factory air box.

Step 7: Remove the factory air filter from the factory air box.

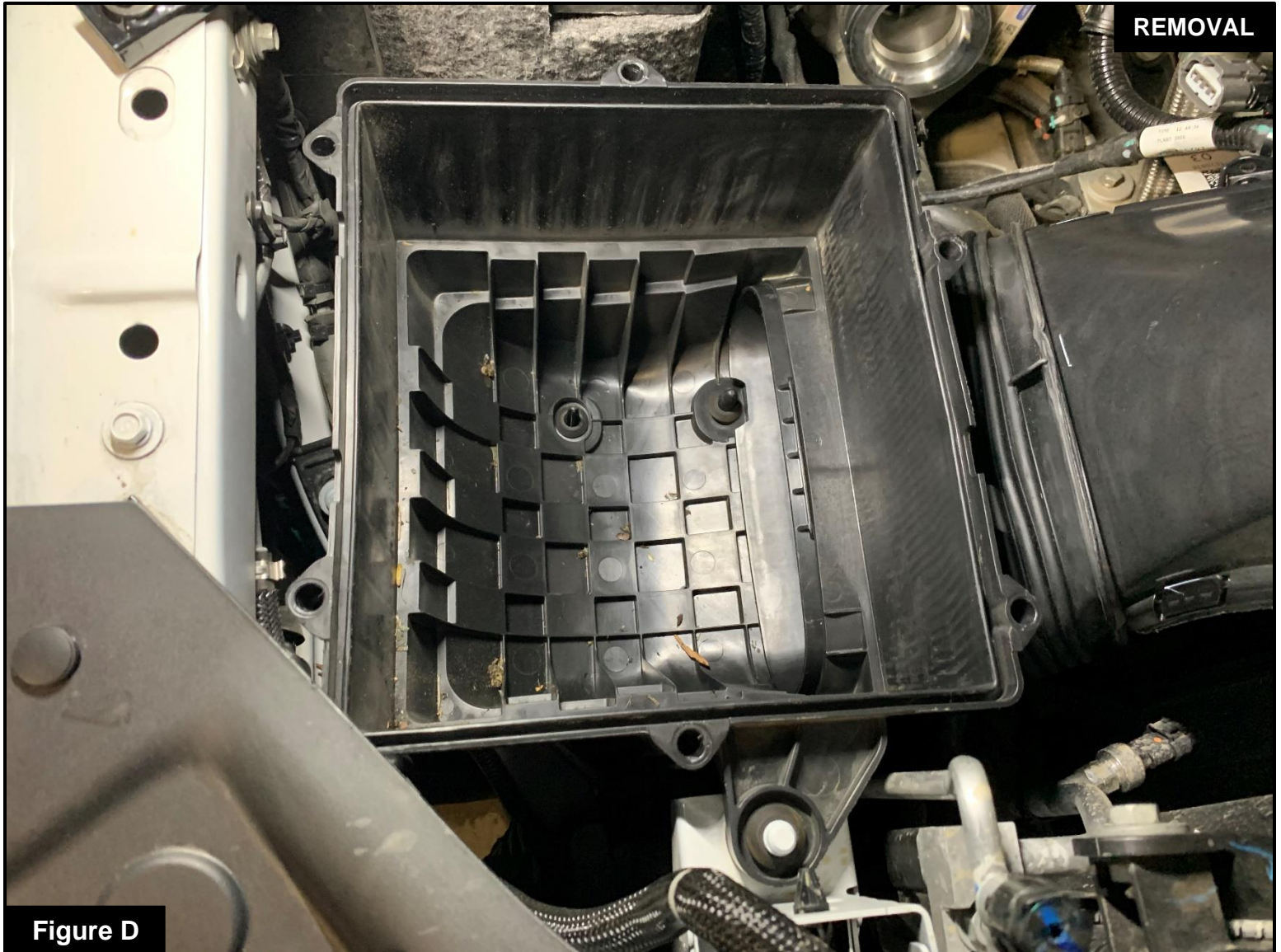

Refer to Figure D for Step 8-9

Step 8: Pull on the lower portion of the factory air box to slide the grommet off the mounts.

Step 9: Disconnect the factory air scoop from the air box and remove the factory air box out of the vehicle.



Figure E

Refer to Figure E for Steps 10

Step 10: Transfer the three factory grommets from the factory air box to the aFe POWER housing.



Figure F

Refer to Figure F for Step 11

Step 11: Install the seal trim on the top edge of the aFe POWER housing.

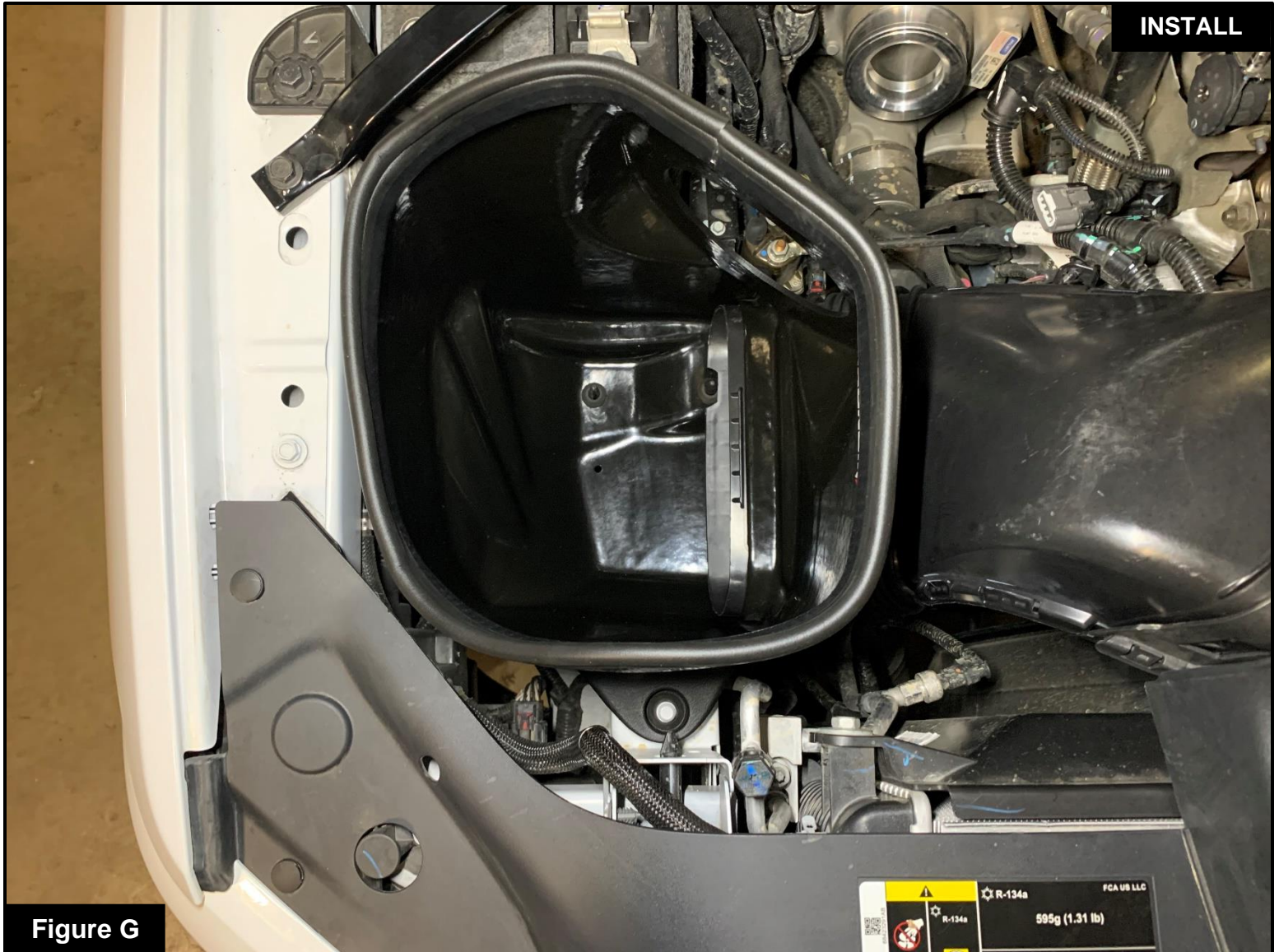

Refer to Figure G for Step 12

Step 12: Install the aFe POWER housing into the vehicle. Slide the factory scoop into the housing until it snaps in. Then press the grommets onto the mounting pegs.



Refer to Figure H for Steps 13

Step 13: Remove the filter clamp from the aFe POWER air filter. Slide the air filter into the aFe POWER housing from the top opening. Then guide the filter flange through the round opening in the housing and snap in the filter. Place the filter clamp on the filter flange but do not tighten at this time.

**Figure I****Refer to Figure I for Steps 14**

Step 14: Transfer the MAF sensor and Temperature sensor from the factory air box to the aFe POWER tube. Secure them using the provided Torx Screws.



Figure J

Refer to Figure J for Steps 15-16

Step 15: Install the coupling onto the tube. Line up the notch on the coupling with the tube.

Step 16: Install the provided clamps over the coupling. Tighten the clamp on the tube side but do not tighten the clamp on the other end yet.



Figure K

Refer to Figure K for Steps 17-18

Step 17: Install the tube assembly over the turbo then into the air filter.

Step 18: Align the tube correctly, then tighten all clamps.



Refer to Figure L for Steps 19

Step 19: Reconnect the MAF and Temperature sensors harness.

 **Make sure that the connections are fully engaged. Usually, connectors make a snapping sound when fully engaged.**



Figure M

Refer to Figure M for Steps 20

Step 20: Verify all clamps and connections are secured. Your installation is now complete. Thank you for choosing aFe POWER!

NOTE: Check all screws, clamps, and connectors are secure after 100-200 miles.



Page left blank intentionally



Page left blank intentionally



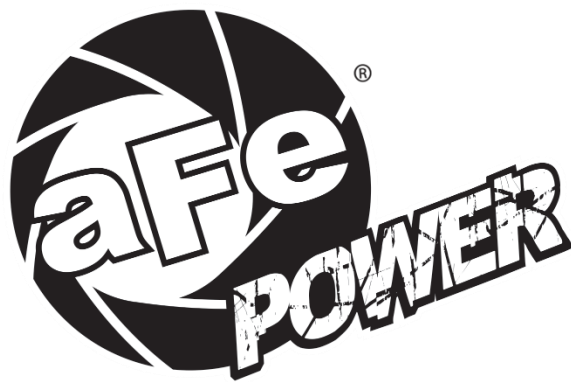

advanced FLOW engineering, Inc.

252 Granite Street Corona, CA 92879

<https://afepower.com/contact>