



Description: Heavy Rate Drag Racing Sway Bar
Part Number: 440-401007-N 1997-2013 C5, C6

Tools Needed:

- 18mm box end wrench
- 15mm open end wrench
- 2 x 9/16 open end wrenches
- 3/4 box end wrench
- 13mm socket and ratchet
- 18mm socket and ratchet
- 6mm Allen
- 5/16 Allen wrench
- 1/4 Allen wrench
- 3/32 Allen wrench
- Torque wrench
- Floor Jack & Jack Stands

Description:

This racing sway bar is engineered to be a lightweight, adjustable drag racing sway bar for C5 and C6 Corvettes, and is not intended to be used on the street, and only used in closed course, racing applications.

What's in the box:

<u>Item</u>	<u>Qty</u>
Assembled Rear Sway Bar	1
Rear Solid Pillow Mounts	2
Rear Solid Bushings	2
Bag of Hardware	1
Flange Nut (M12x1.75)	2
Flange Nut (3/8-24)	2
Jam Nut, LH	2
Jam Nut, RH	2
Socket Head Cap Screw	2
Spacer	2
Turnbuckle	2
Studded Heim Joint, RH	2
Heim Joint, LH	2

Difficulty of Installation: **Beginner** |-----x-----| **Advanced**

Reason: This product is a very straight forward to install and requires only basic tools.

Expected Installation Time: 1 Hour.

Step 1: Rear Sway Bar Removal

Remove the nuts attaching the end link to the lower control arm using an 18mm box end wrench and a 6mm Allen. Using a 15mm wrench and an 18mm socket and ratchet remove the two lower nuts and two upper bolts from the sway bar bushing brackets. Remove the sway bar and end link assembly.

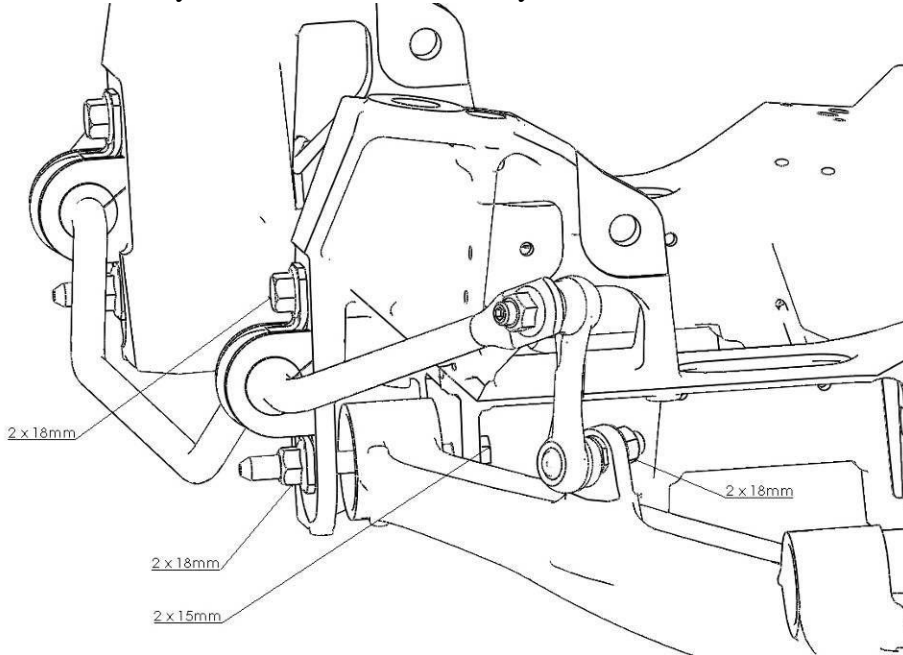

Pfadt Series Sway Bar Installation Procedure

Step 1: Assemble End Links

Assemble each of the four end links as shown below. The end of the turnbuckle with left hand threads is denoted by the incomplete wrench flats. Adjust two of the end links to approximately 80 mm for the rear sway bar. It is not necessary to tighten the jam nuts at this time.

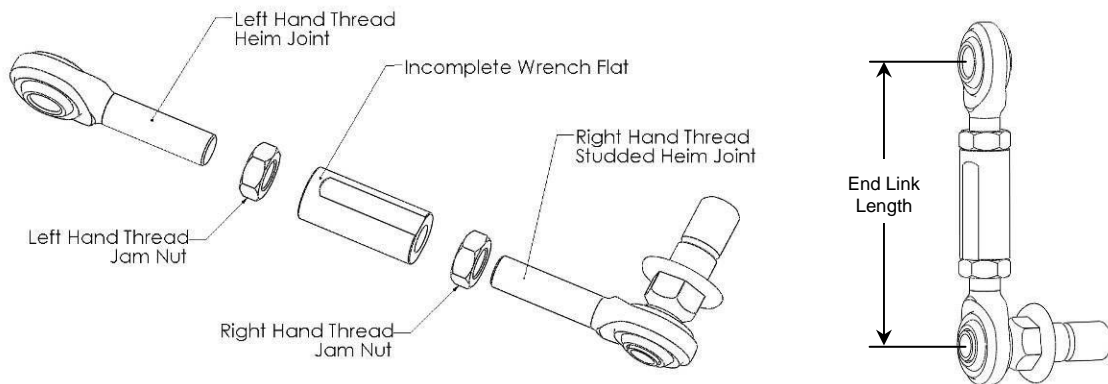

Step 2: Install Rear End Links

Install one of the 80mm long end link assemblies onto each of the rear lower control arms. Use a 15mm open end wrench on the flats of the heim joint stud to prevent it from rotating as you tighten the nut using an 18mm socket. Torque to 76 N-m (56 ft-lbs).

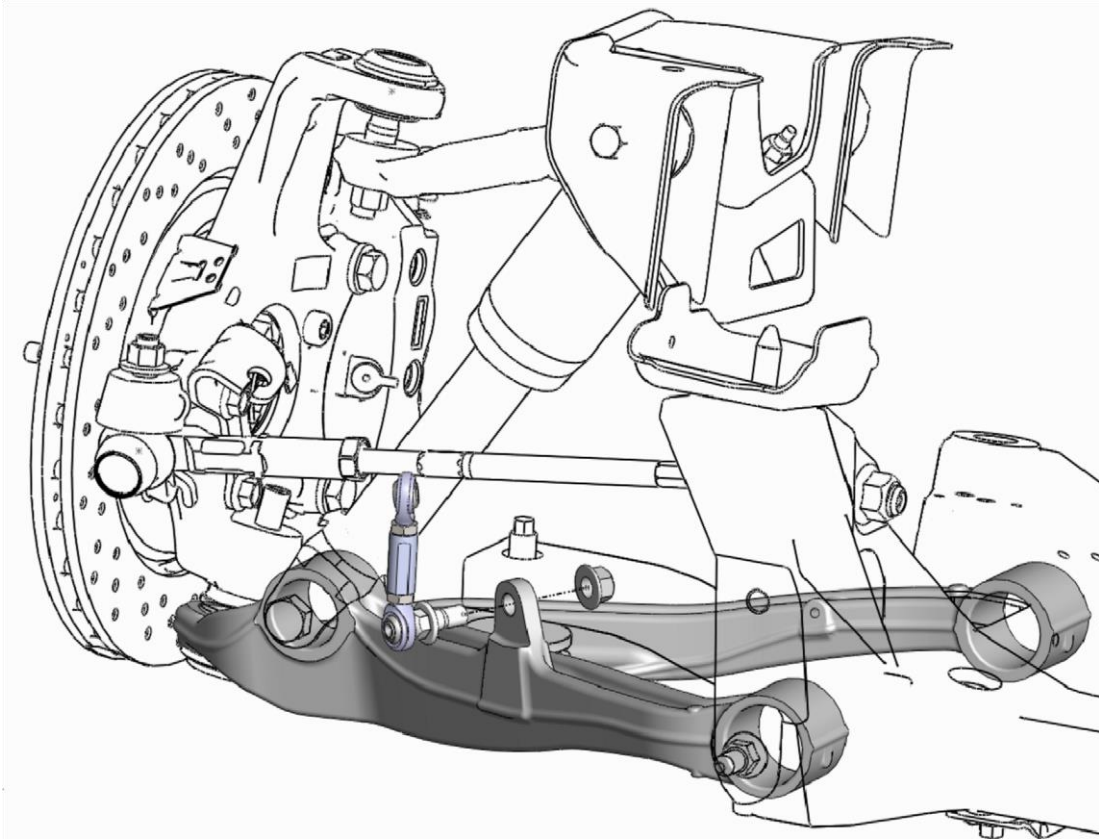

NOTE: To prevent thread galling, do not use a high-speed driver such as an impact gun on the flange nut. Only tighten by hand and torque to spec.

Step 3: Install Rear Sway Bar

Using the factory bolts, and nuts, install the sway bar onto the subframe by positioning the rear pillow blocks, and bushings over the factory bolt holes. Torque the mounting bolts to 65 N-m (49 ft-lbs) and mounting nuts to 95 N-m (70 ft-lbs). Test the movement of the sway bar. You should be able to rotate the bar by hand with moderate force on the ends of the arms. If it's too tight, place a 1/2" or 12mm washer on the bolts between the brackets and the frame and repeat the process.

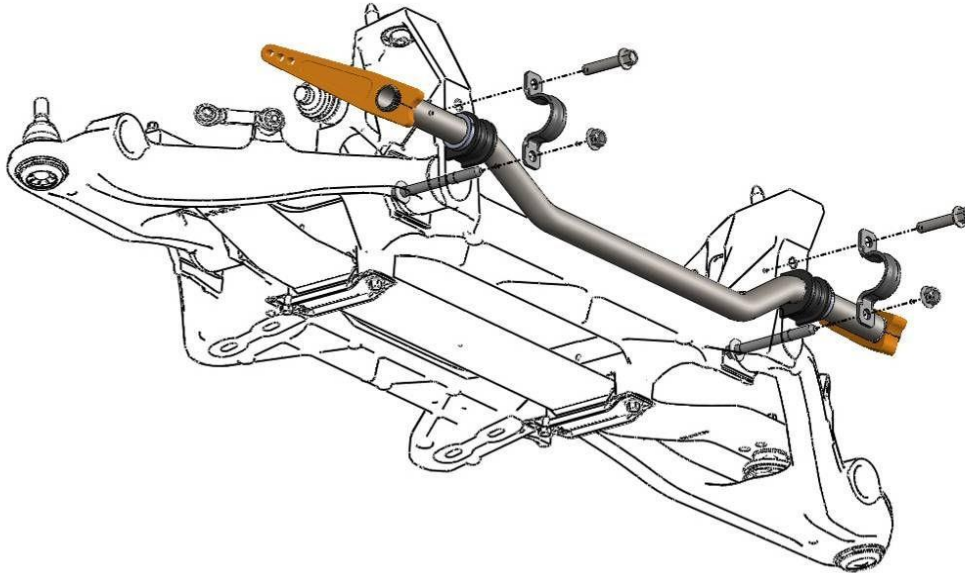

Center the sway bar on the subframe so that the length from the bushing bracket to the end of the bar is the same on both sides. Slide the centering rings next to the bushings and lock in place using the provided set screws. Tighten the set screws with a 3/32 Allen wrench.

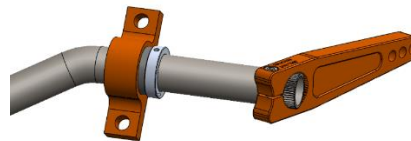
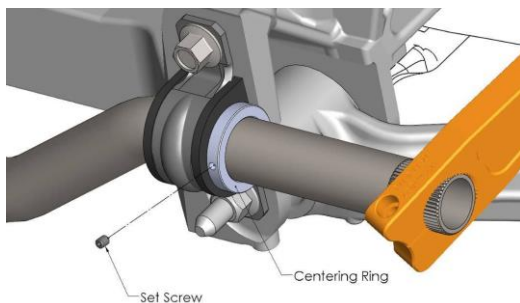

Attach the sway bar arms to the end links. **Place the spacer between the arm and the end link** as shown below and secure with the bolt and nut. The spacer must be properly installed to allow the heim joint to articulate adequately through full suspension travel without binding. Torque the bolt to 45 N-m (33 ft-lbs).

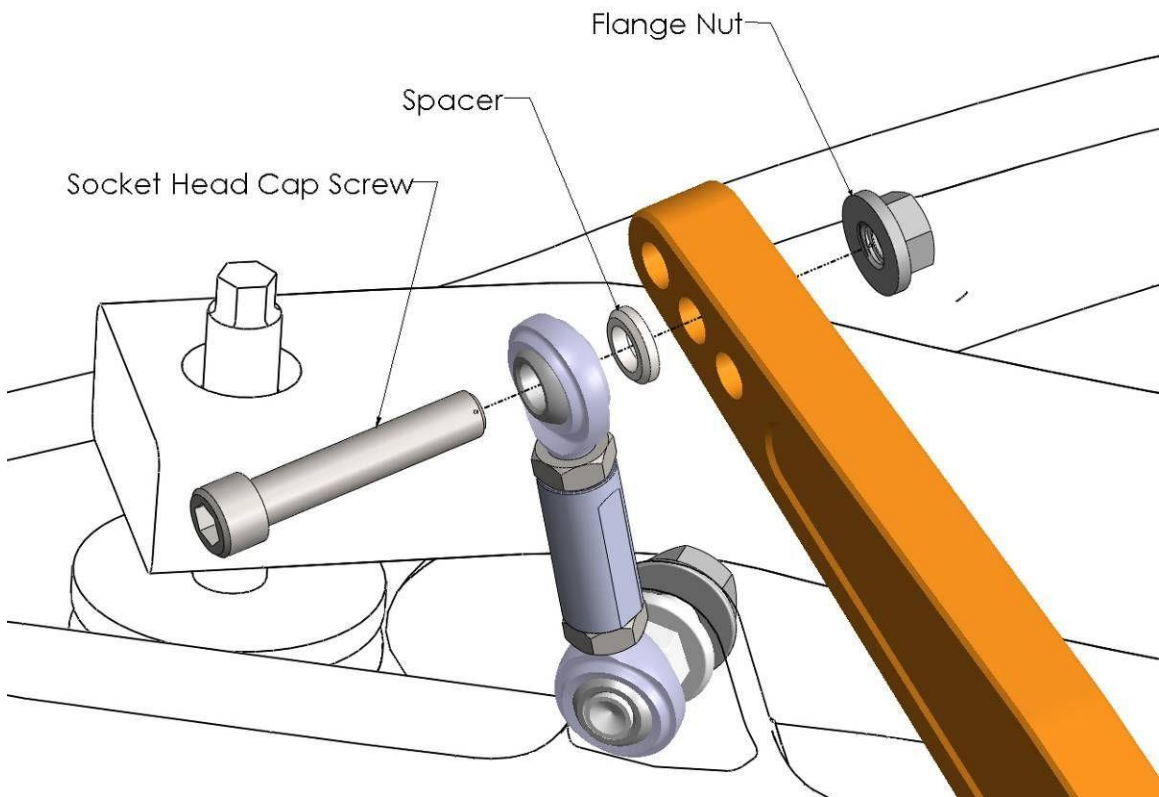
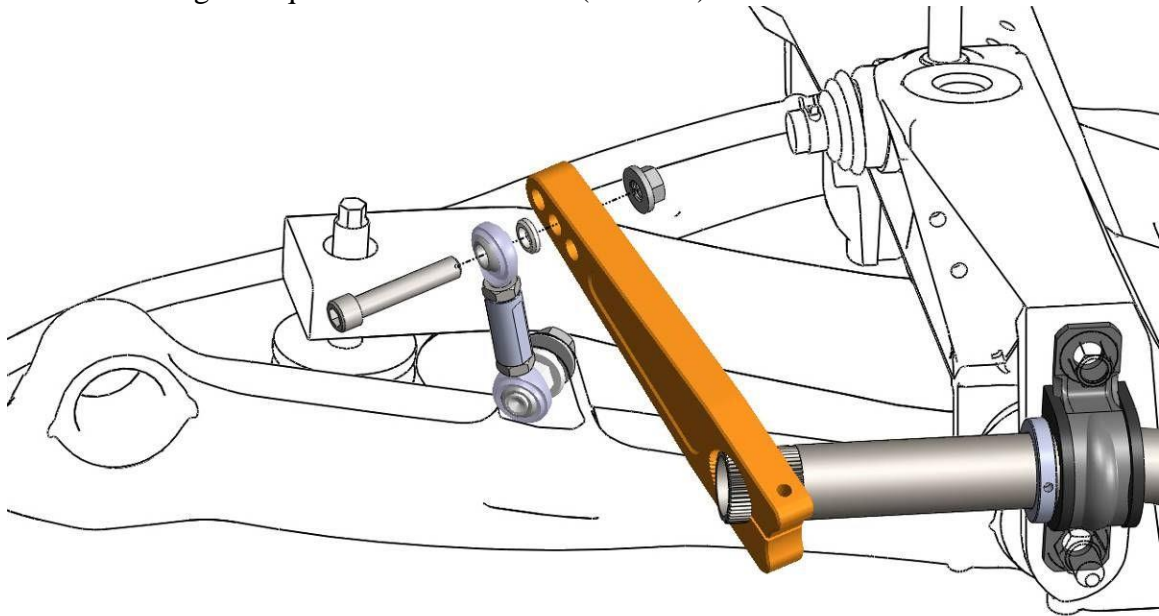

Initial Setup

For best performance, remove any pre-load in the sway bar while the suspension is loaded. This is best done on a four post lift, but it is also possible to set the car down on blocks or ramps so that the end links can be accessed while the suspension is loaded. Disconnect the end link from the sway bar arm at one end of the sway bar. Adjust the length of the end link so that the bolt can be slipped through the end link and the hole in the sway bar arm without having to apply any force to the arm to get the parts to line up perfectly.

After the end link length is adjusted to remove any preload, lock down the length by tightening the jam nuts.

Fastener Torque Specifications

Application	Torque Spec	
	Metric	English
End Link Stud Nuts	76 N-m	56 lb-ft
End Link to Sway Bar Arm Bolts	45 N-m	33 lb-ft
Sway Bar Arm Pinch Bolts	18 N-m	13 lb-ft
Rear Bushing Bracket Bolts	65 N-m	49 lb-ft
Rear Bushing Bracket Nuts	95 N-m	70 lb-ft

Please contact aFe Control Customer Support with any questions!

Sway Bar Arm Installation Procedure

Your Pfadt Series sway bars were shipped with the arms assembled onto the bar, but if you have to remove and re-install the arms for any reason, follow this procedure.

Insert the installation tool into the end of the sway bar and use it to help align the splines in the arm to the splines on the sway bar. On the front sway bar, the angle between the dip in the bar and the slot in the arm for the pinch bolt should be roughly 90 degrees.

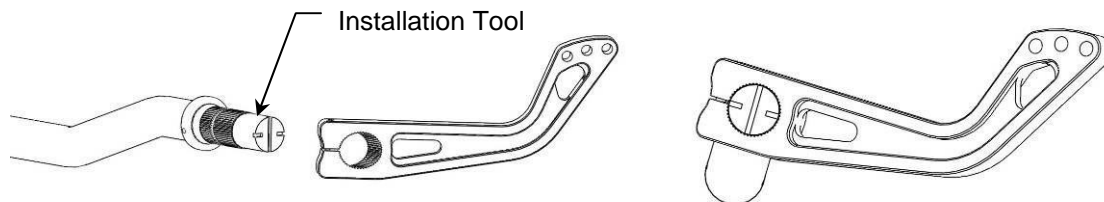

On the rear sway bar, the angle between the dip in the bar and the slot in the arm should be roughly 55 degrees.

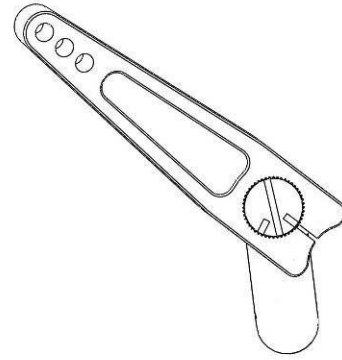
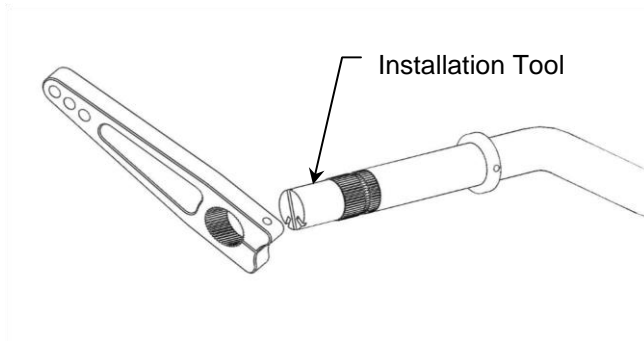

Align the pinch bolt hole with the groove in the splines on the end of the bar and install the pinch bolt. Torque to 18 N-m (13 ft-lbs).

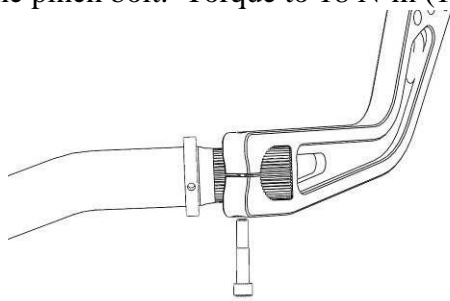

Front Pinch Bolt

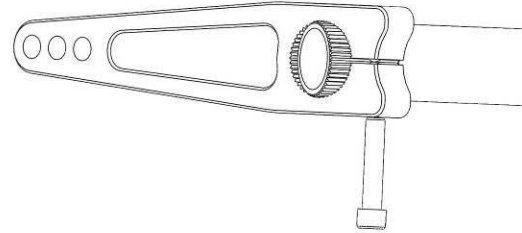

Rear Pinch Bolt

Repeat this procedure for the other side. It is helpful to place the bar and arms on a flat surface to help index the arms from side to side. Some amount of misalignment is typical and is not a concern. This misalignment will be accounted for with the adjustable end links.



1960 S Carlos Ave Bldg 10, Unit 6
Ontario, CA 91761
951-493-7128
www.aFecontrol.com