



Description: Heavy Rate Racing Sway Bar Service Kit
Part Number: 441-401001-N, Front
441-401002-N Rear

Tools Needed:

- 18mm box end wrench
- 15mm open end wrench
- 2 x 9/16 open end wrenches
- 3/4 box end wrench
- 13mm socket and ratchet
- 18mm socket and ratchet
- 6mm Allen
- 5/16 Allen wrench
- 1/4 Allen wrench
- 3/32 Allen wrench
- Torque wrench
- Floor Jack & Jack Stands

Description:

This service kit is designed to replace the commonly worn or damaged components for the Heavy Rate Racing Sway Bars.

Sway Bar Arm Installation Procedure

Your Pfadt Series sway bars were shipped with the arms assembled onto the bar, but if you have to remove and re-install the arms for any reason, follow this procedure.

Insert the installation tool into the end of the sway bar and use it to help align the splines in the arm to the splines on the sway bar. On the front sway bar, the angle between the dip in the bar and the slot in the arm for the pinch bolt should be roughly 90 degrees.

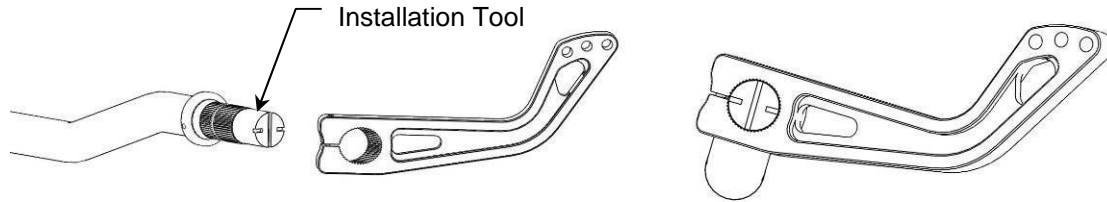

On the rear sway bar, the angle between the dip in the bar and the slot in the arm should be roughly 55 degrees.

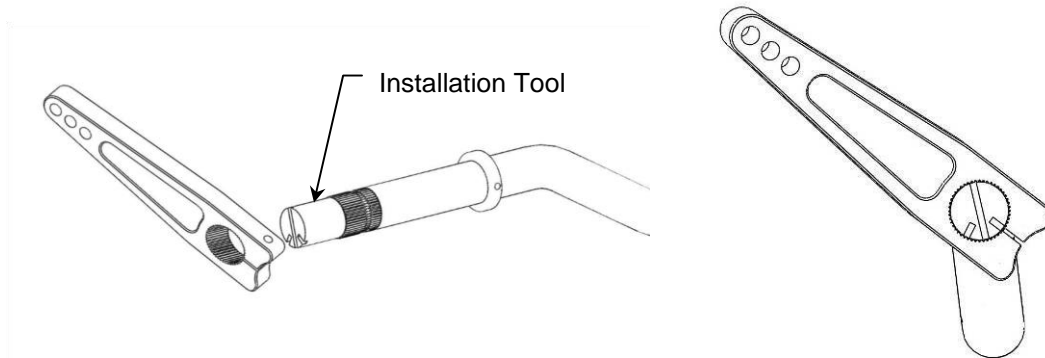

Align the pinch bolt hole with the groove in the splines on the end of the bar and install the pinch bolt. Torque to 18 N-m (13 ft-lbs).

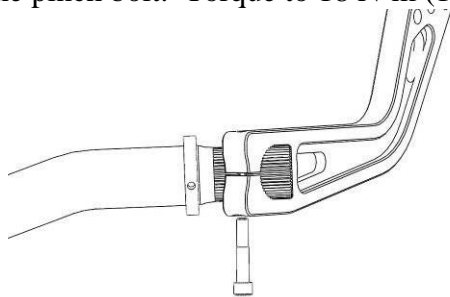

Front Pinch Bolt

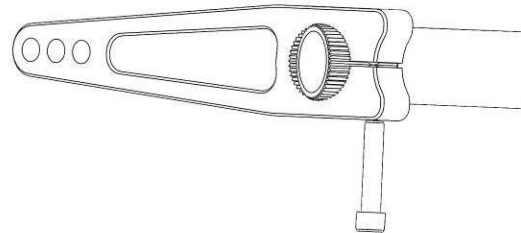

Rear Pinch Bolt

Repeat this procedure for the other side. It is helpful to place the bar and arms on a flat surface to help index the arms from side to side. Some amount of misalignment is typical and is not a concern. This misalignment will be accounted for with the adjustable end links.

End Link Assembly

Assemble each of the end links as shown below. The end of the turnbuckle with left hand threads is denoted by the incomplete wrench flats. Adjust two of the end links to approximately 90 mm for the front sway bar and two of them to approximately 80 mm for the rear sway bar. It is not necessary to tighten the jam nuts at this time.

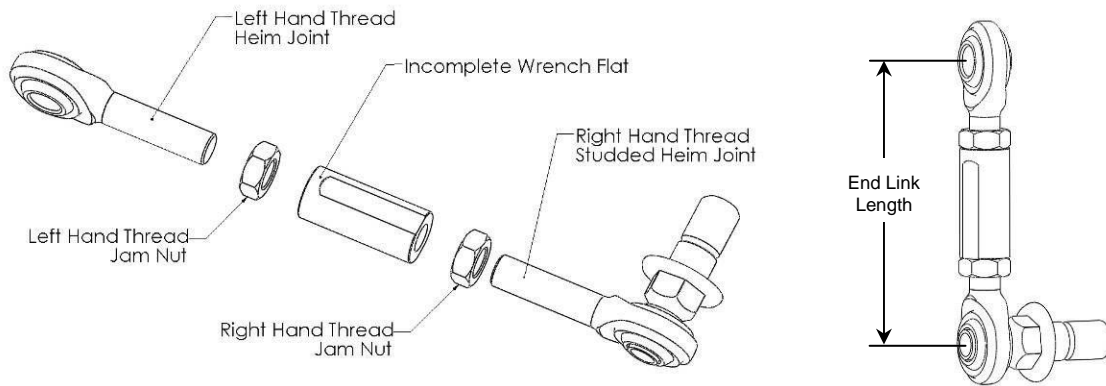

Install Front End Links

Install one of the 90mm long end link assemblies onto each of the front lower control arms. Use a 15mm open end wrench on the flats of the heim joint stud to prevent it from rotating as you tighten the nut using an 18mm socket. Torque to 76 N-m (56 ft-lbs).

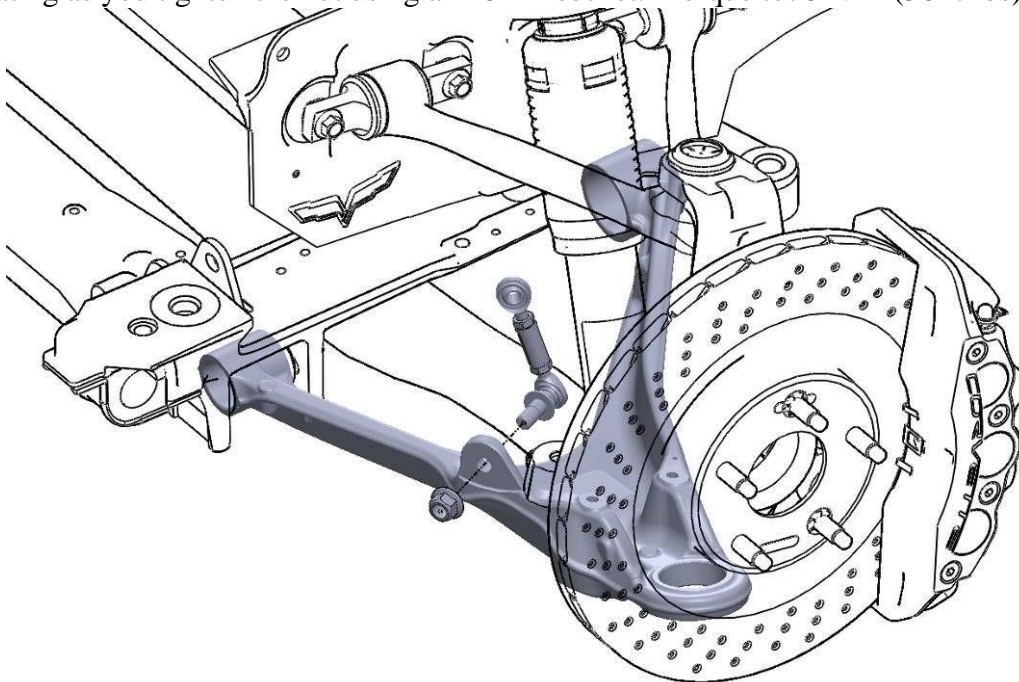

OTE: To prevent thread galling, do not use a high-speed driver such as an impact gun on the flange nut. Only tighten by hand and torque to spec.

Center the sway bar on the subframe so that the length from the bushing bracket to the end of the bar is the same on both sides. Slide the centering rings next to the bushings and lock in place using the provided set screws. Tighten the set screws with a 3/32 Allen wrench.

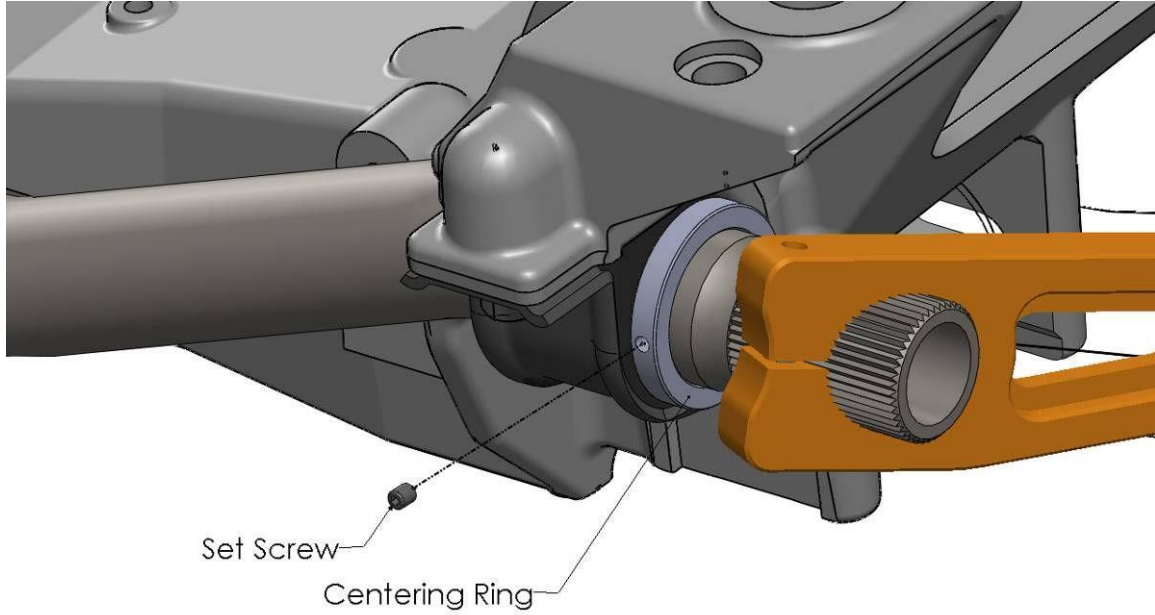

Attach the sway bar arms to the end links. **Place the spacer between the arm and the end link** as shown below and secure with the bolt and nut. The spacer must be properly installed to allow the heim joint to articulate adequately through full suspension travel without binding. Torque the bolt to 45 N-m (33 ft-lbs).

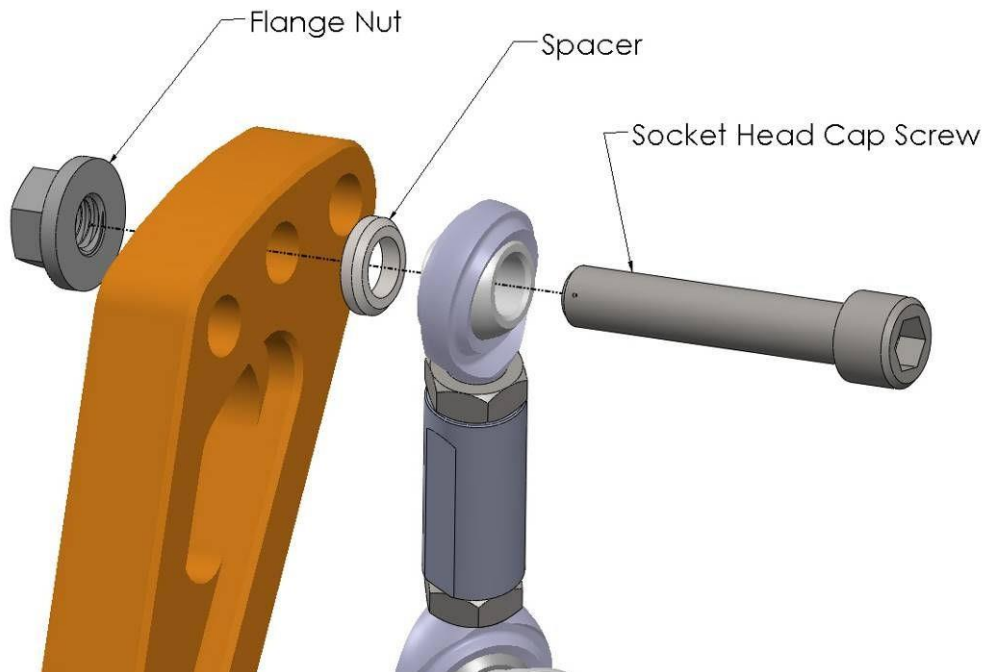
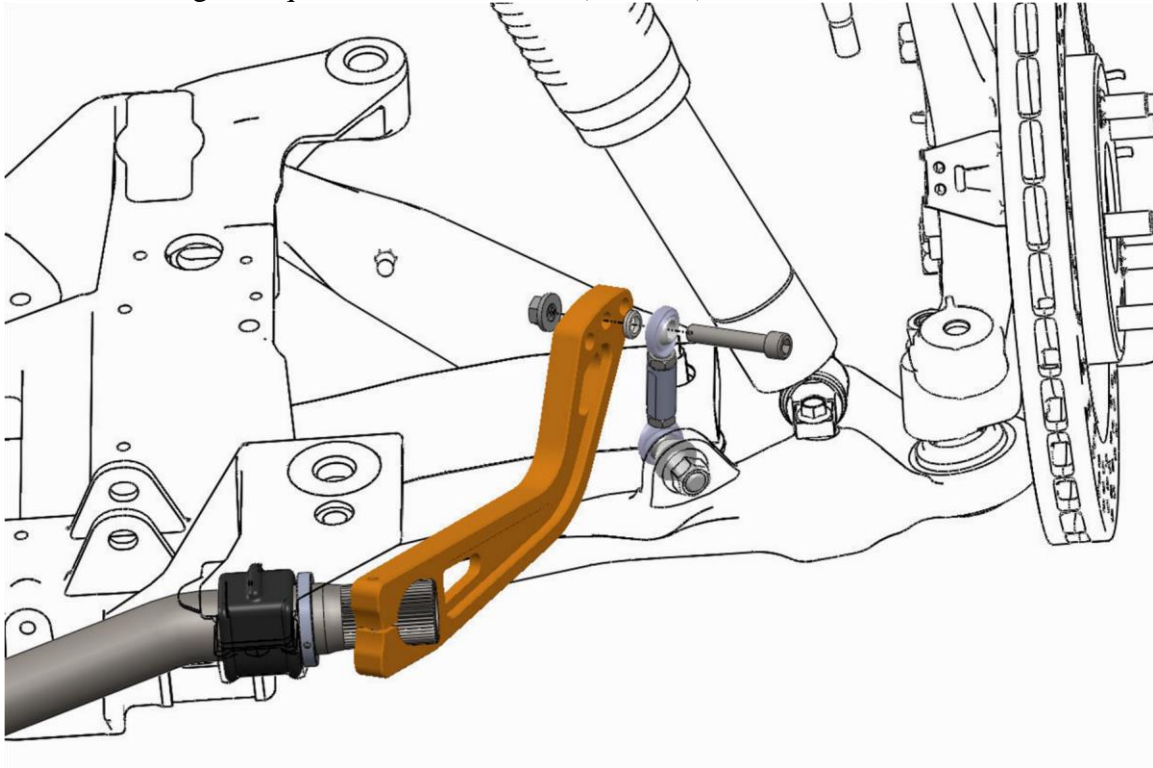

Install Rear End Links

Install one of the 80mm long end link assemblies onto each of the rear lower control arms. Use a 15mm open end wrench on the flats of the heim joint stud to prevent it from rotating as you tighten the nut using an 18mm socket. Torque to 76 N-m (56 ft-lbs).

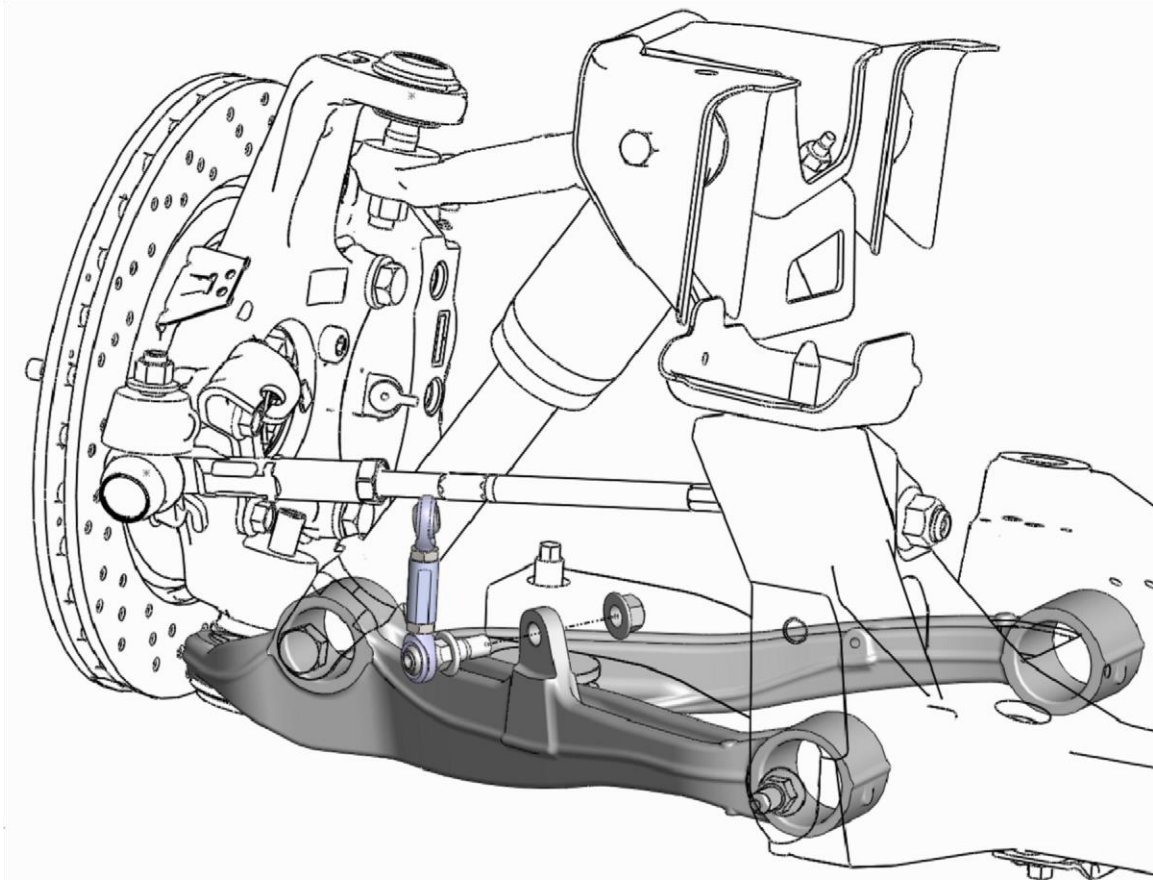

O**T****E:** To prevent thread galling, do not use a high-speed driver such as an impact gun on the flange nut. Only tighten by hand and torque to spec.

Center the sway bar on the subframe so that the length from the bushing bracket to the end of the bar is the same on both sides. Slide the centering rings next to the bushings and lock in place using the provided set screws. Tighten the set screws with a 3/32 Allen wrench.

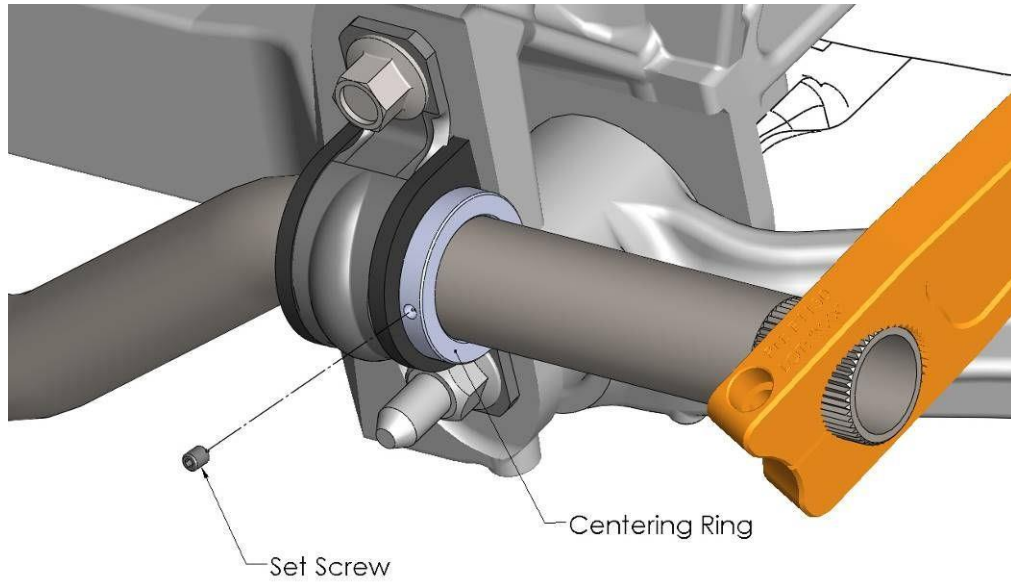

Attach the sway bar arms to the end links. **Place the spacer between the arm and the end link** as shown below and secure with the bolt and nut. The spacer must be properly installed to allow the heim joint to articulate adequately through full suspension travel without binding. Torque the bolt to 45 N-m (33 ft-lbs).

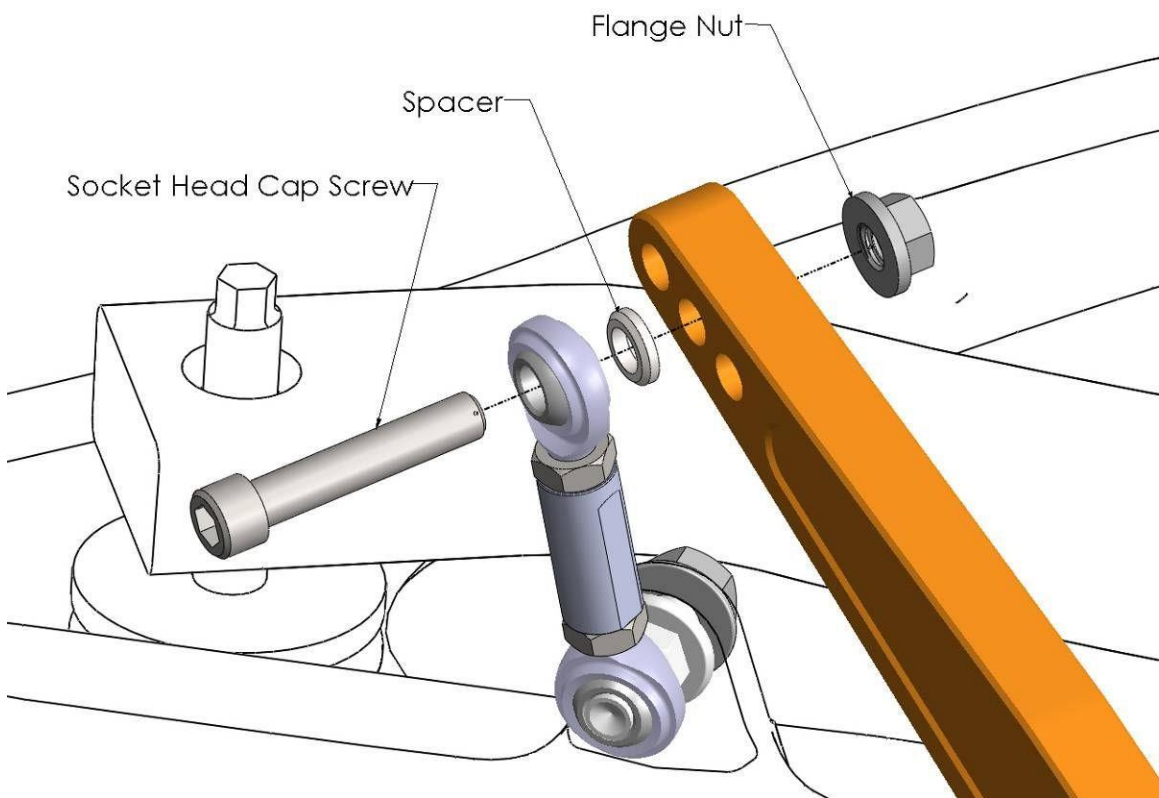
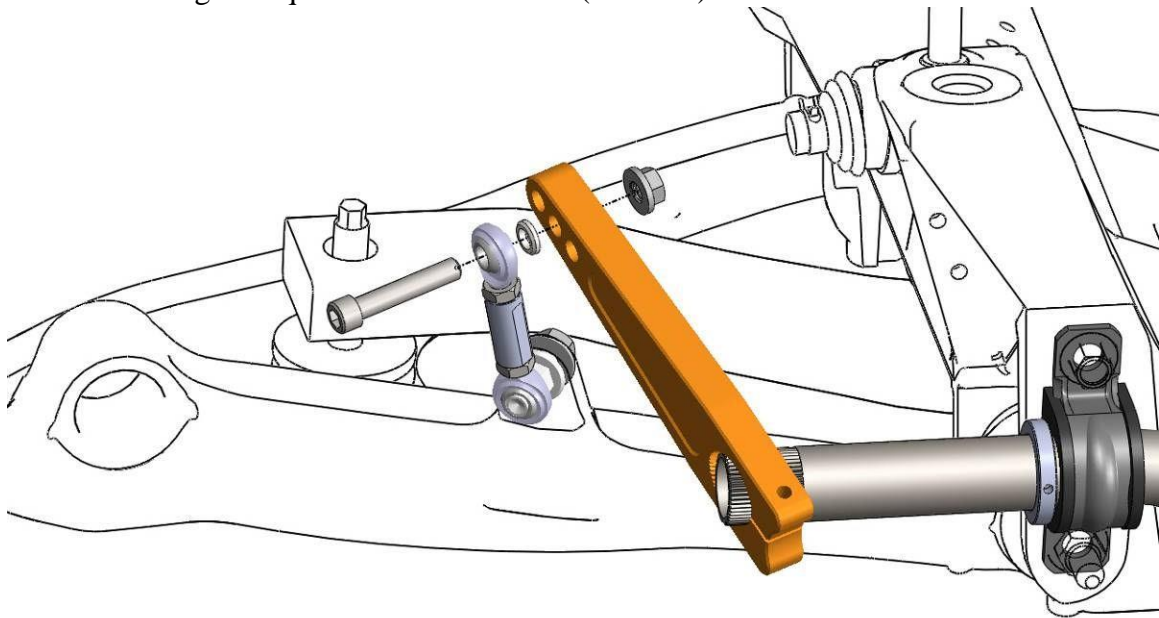

Initial Setup

For best performance, remove any pre-load in the sway bar while the suspension is loaded. This is best done on a four post lift, but it is also possible to set the car down on blocks or ramps so that the end links can be accessed while the suspension is loaded. Disconnect the end link from the sway bar arm at one end of the sway bar. Adjust the length of the end link so that the bolt can be slipped through the end link and the hole in the sway bar arm without having to apply any force to the arm to get the parts to line up perfectly.

After the end link length is adjusted to remove any preload, lock down the length by tightening the jam nuts.

For the initial setting of the sway bars we recommend **position 2** for both the front and rear sway bars. For most applications this will be a satisfactory setting and is a good starting point for all cars.

Fastener Torque Specifications

Application	Torque Spec	
	Metric	English
End Link Stud Nuts	76 N-m	56 lb-ft
End Link to Sway Bar Arm Bolts	45 N-m	33 lb-ft
Sway Bar Arm Pinch Bolts	18 N-m	13 lb-ft
Front Bushing Bracket Bolts	58 N-m	43 lb-ft
Rear Bushing Bracket Bolts	65 N-m	49 lb-ft
Rear Bushing Bracket Nuts	95 N-m	70 lb-ft

Please contact aFe Control Customer Support with any questions!

Sway Bar Tuning Guidelines

Sway bars are your largest tuning tool and are capable of affecting the balance of the car during each phase of a corner: corner-entry, mid-corner and corner-exit. However, sway bar tuning is especially useful for adjusting mid-corner behavior. Corner-entry and corner-exit are considered transition periods. During these transition periods the shocks are capable of modifying the balance of the car. At mid-corner, shock settings have no affect on balance and adjustments are made with the sway bar. In other words, sway bars could correct a corner-entry or corner-exit balance problem but, shocks can not correct a mid-corner balance problem. This is the reason that sway bar tuning should ideally be done during mid-corner.

When tuning sway bars it is best to find a long constant radius turn at which you can incrementally increase speed until the limit of traction is found. There are three possible scenarios at the limit of traction.

1. The front tires exceed their limit of traction first. This condition is commonly called under-steer, push or tight.
2. The rear tires exceed their limit of traction first. This condition is commonly called over-steer, tail-happy or loose.
3. The front and rear tires exceed their limit of traction at the same moment. This condition is commonly called a four-wheel-drift or neutral balance.

After you have determined the behavior of the car it is possible to change this balance by changing the sway bar settings.

Let's take a look at case one for a moment. The front tires are being asked to carry a cornering load higher than they are capable of while the rear tires are being asked to carry a cornering load lower than they are capable of. By either moving the front sway bar to a softer setting or the rear sway bar to a stiffer setting you will remove some of the cornering responsibility from the front tires and add it to the rear tires.

The general rule of sway bar tuning is to soften the end that needs additional traction. It is also equally as effective to stiffen the end that needs less traction. Typically in the Corvette we tune with the rear sway bar because adjustments on the rear sway bar are easier to perform at the track.

Each arm is marked with numbers corresponding to each adjustment hole. Lower numbers are a softer setting. Higher numbers are a stiffer setting.





191 Granite Street Ste C
Corona, CA 92879
951-493-7128
www.aFecontrol.com