

1993-2002 GM CAMARO/FIREBIRD - V6 3.4/3.8L

DIAGRAM 1

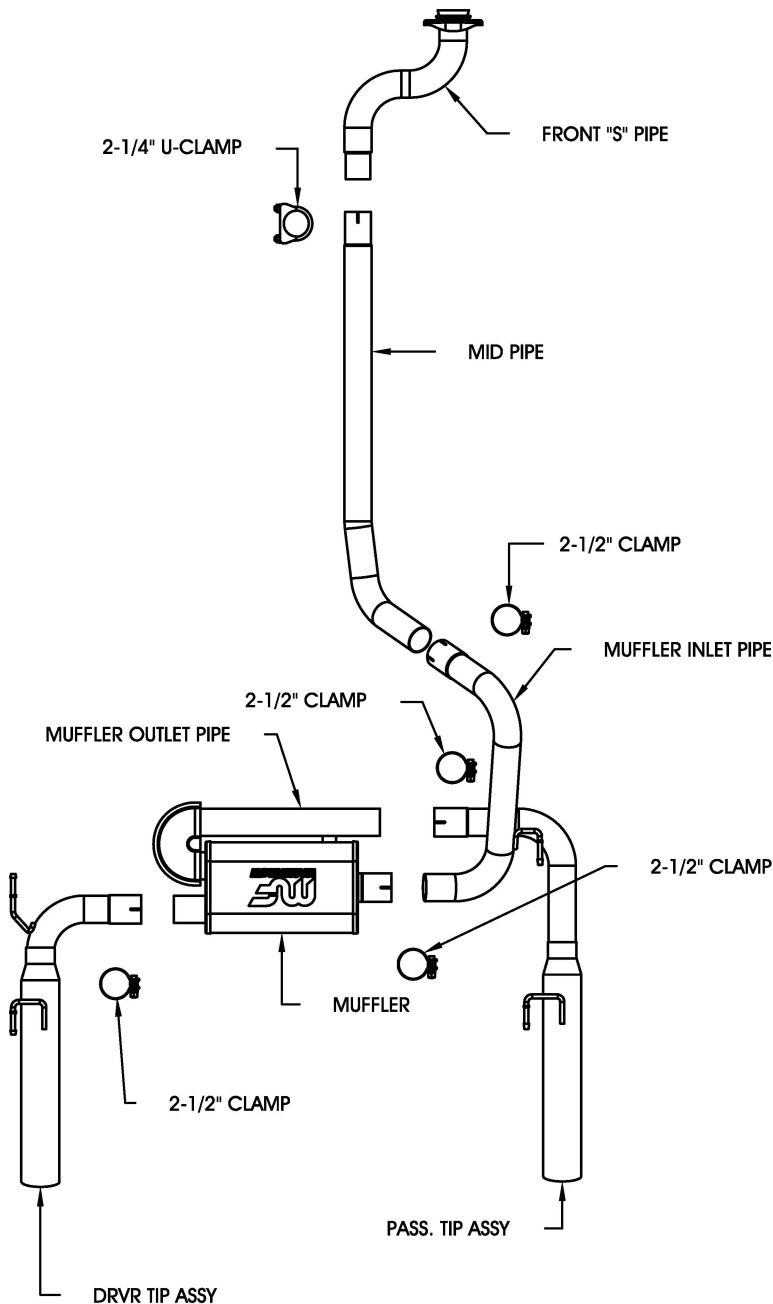

Warning: When working on under or around any vehicle exercise caution. Please allow the vehicle's exhaust system to cool before removal, as exhaust system temperatures may cause severe burns. If working without a lift, always consult vehicle manual for correct lifting specifications. Always wear safety glasses and ensure safe work area. Serious injury or death could occur if safety measures are not followed.

Step 1: (Carefully read all instructions before installation) To remove the OEM exhaust system you will need to cut the pipe just in front of the rear axle. Unbolt all hangers on the tailpipes and muffer, then remove from the vehicle (Do not damage the OEM rubber insulators, as they will be re-used to mount the new system). Do not discard the OEM fasteners, as they will be re-used to mount the new system. Unbolt the clamp where the OEM middle pipe meets the catalytic converter and remove the pipe from the vehicle.

Step 2: Layout all parts of the new system as shown in the diagram. Install the tailpipe hanger brackets (See Diagram 2 for installation of hanger brackets). Fasten the front "S" pipe to the catalytic converter using the supplied 2-bolt flange and the OEM fasteners (On 98 and newer vehicles the front "S" pipe is welded to the converter. Begin installation at the midpipe). Leave all components loose for final adjustment. Working rearward, install the Mid-pipe and muffer inlet pipe using the supplied clamps, and the OEM fasteners from the hangers. Install the tailpipes by fitting the welded hangers into the rubber insulators. Mount the muffer to the muffer inlet pipe, tailpipes and muffer outlet pipe using the supplied clamps.

Step 3: With all components and fasteners still mounted loosely, adjust the system for overall aesthetics and clearance of frame & bodywork. (MAGNAFLOW recommends at least 1/2" of clearance between the exhaust tips and any body panels to avoid heat related bodywork damage or fire.)

Step 4: Once a final position has been chosen for the new system, evenly tighten all fasteners from front to rear. The supplied band clamps must be VERY tight to properly align the pipes and prevent leaks (Approximately 40 ft-lbs). U-bolt clamps should be tightened to approximately 30-35 ft-lbs. Inspect all fasteners after 25-50 miles of operation and re-tighten if necessary.

Technical support: 1-800-959-9226 ext. 4500

*MAGNAFLOW Performance Exhaust recommends professional installation on all their products

1993-2002 GM CAMARO/FIREBIRD - V6 3.4/3.8L

DIAGRAM 2

Warning: When working on under or around any vehicle exercise caution. Please allow the vehicle's exhaust system to cool before removal, as exhaust system temperatures may cause severe burns. If working without a lift, always consult vehicle manual for correct lifting specifications. Always wear safety glasses and ensure safe work area. Serious injury or death could occur if safety measures are not followed.

Slide the threaded mount plate into the pre-cut holes in the frame. Position the threaded mount plate in the frame until the threaded holes of the mount plate are line up with the pre-cut holes in the frame. Fasten the hanger brackets to the frame using the supplied fasteners in the order shown in the diagram. The welded hanger should face forward and to the center of the vehicle.

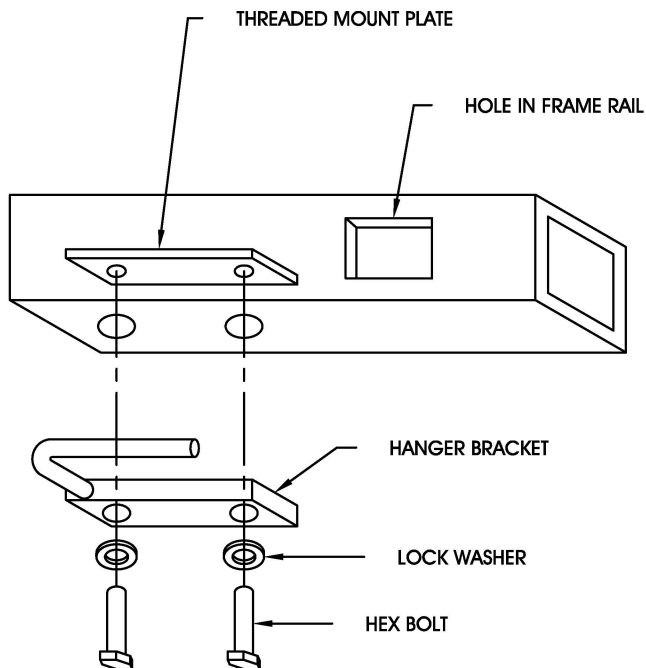

*MAGNAFLOW Performance Exhaust recommends professional installation on all their products

Technical support: 1-800-959-9226 ext. 4500