

# Installation instructions For set # 15.1101

## Volkswagen Engine & Transmission Mount Set



1131 VIA CALLEJON, SAN CLEMENTE, CA 92673

It is recommended that if you are unfamiliar with this type of work that you refer to a qualified service center specializing in this type of work. It is also recommended that if you choose to do this work yourself that a factory service manual be obtained for the proper procedures pertaining to removal, replacement and proper torque specifications for your vehicle. This instruction set is intended as a guideline for the safe installation of Energy Suspension's polyurethane bushings, once you have removed the factory components from your vehicle.

**1.** Disconnect the battery and block the front wheels. **2.** The engine must be removed to replace the front and rear mounts. Consult your V.W. repair manual for proper procedures on the engine removal and moving the transaxle to install the front transmission mount. **3.** After the engine has been removed and the transmission moved rearward, install #1028 front transmission mount. Use Drawing #1 for reference of sleeves and washers. **NOTE:** The ground strap must be between body and mount. The word "TOP" indicates topside of the mount. **4.** Drawing #2 shows proper placement of sleeves, washers, bolts and nuts into the polyurethane engine mounts #1029. **5.** Install side mounts #1029 onto transaxle housing. Torque to factory specifications. **6.** Install transmission carrier onto side mounts. Start with one side, progressing to the next. Torque to factory specifications. **7.** Tighten anything else previously loosened or removed. Install engine. **8.** Some models will require the rear wheels to be realigned professionally.

DRAWING #1

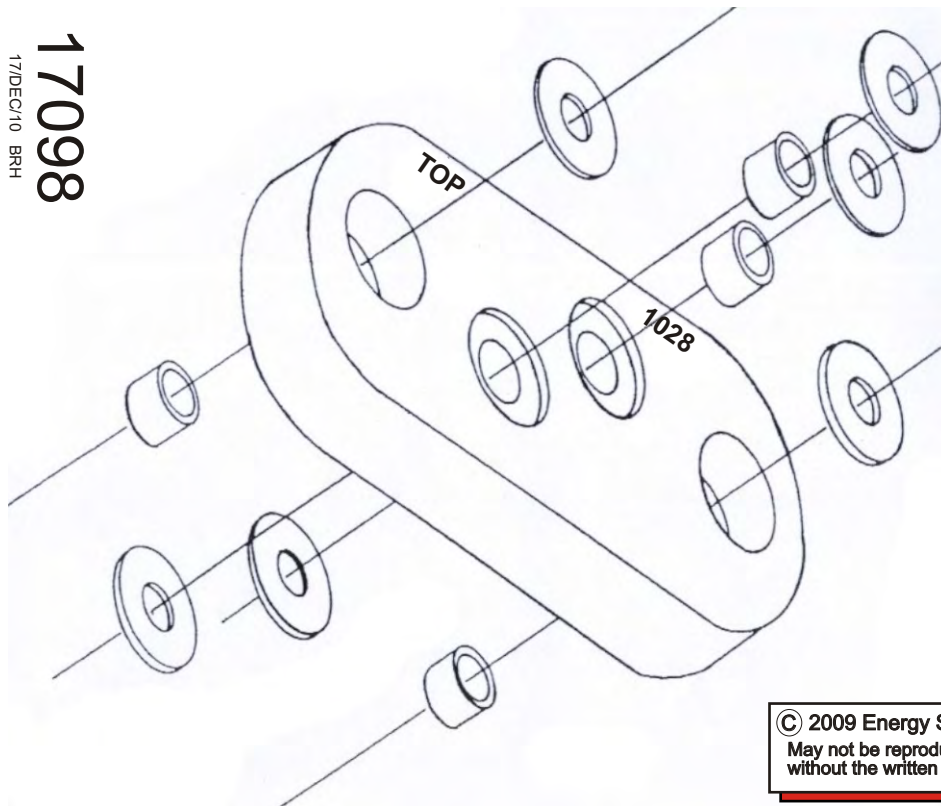

DRAWING #2

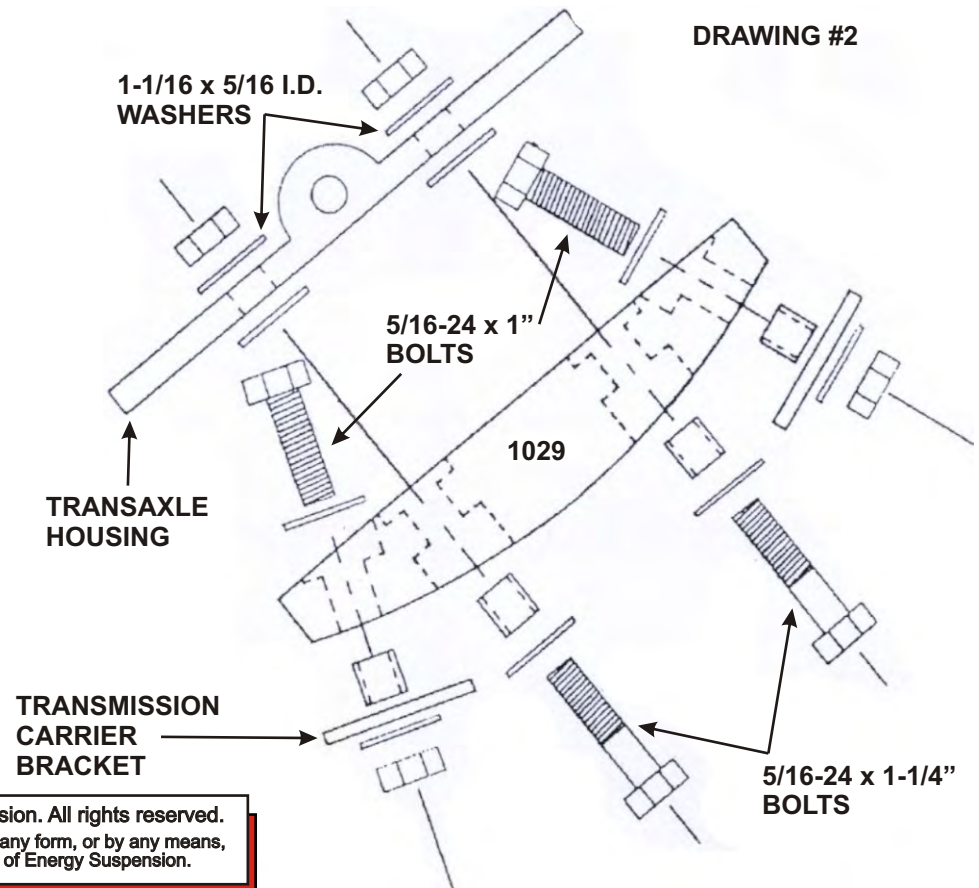

© 2009 Energy Suspension. All rights reserved.  
May not be reproduced, in any form, or by any means,  
without the written consent of Energy Suspension.