

Installation for Ford Mustang GT

PNs 60705, 60661, 60715, 140742*, 140743*, 140745, 140746, 140807



******* Please compare the parts in the box with the bill of materials provided *****
to assure that you have all the parts necessary for this installation.**

These instructions have been written to help you with the installation of your Borla Performance Exhaust System. Please read this document completely before beginning the installation of your system.

To ensure this part number fits your specific model year, please visit our website for the latest model year listings at www.BORLA.com

Thank you for purchasing a Borla Performance Exhaust System.

Borla Performance Resonator Option (PN 60661) has LARGER DIAMETER TUBING and is designed specifically for (below) Cat-Back™ Exhaust Systems (PN's 140742, 140743, 140745, 140746).

PN 60661 IS NOT COMPATIBLE WITH THE STOCK EXHAUST SYSTEM (with smaller diameter tubing).

Borla Performance Cat-Back™ Exhaust Systems (PNs 140742*, 140743*, 140745, 140746, 140807) are designed for the Ford Mustang GT equipped with a 5.0L V8 engine, automatic or manual transmissions. Please note that of the part numbers listed, 140807 is the ONLY one compatible with convertible Mustang GTs.

**Equipped with Active Valve Performance Exhaust option*

Borla Performance SwitchFire™ X-Pipe Upgrade (PN 60715) has LARGER DIAMETER TUBING and is designed specifically for Borla Performance Cat-Back™ Systems (PNs 140742, 140743, 140745, 140746).

PN 60715 IS NOT COMPATIBLE WITH THE STOCK EXHAUST SYSTEM (with smaller diameter tubing).

Borla Performance PN 60705 is designed to complement Borla Performance Axle-Backs for the Mustang GT to create a custom Cat-Back system. Pair 60705 with PN's 11951 and 11953.

Borla Performance Industries recommends that an exhaust shop or professional after market parts installer, who has all the necessary equipment, tools and experienced personnel needed for proper installation, should perform the installation of this system. However, if you decide to perform the installation, we recommend someone should help you. Ensure the installer uses all under car safety precautions including eye protection.

Please take time to read and understand the following...

By installing your Borla Performance Exhaust System, you indicate that you have read this document and you agree with the terms stated below.

It is the responsibility of the purchaser to follow all installation instruction guidelines and safety procedures supplied with your Borla Performance Exhaust System.

Borla Performance Industries assumes no responsibility for damages occurring from misuse, abuse, improper installation, improper operation, lack of responsible care, or all previously stated reasons resulting from incompatibility with other manufacturer's products and/or systems.

Included with your Borla Performance Exhaust System is a warranty card. Please read it carefully before you begin any work on your vehicle. If you should have any questions regarding our warranty policy, installation, or any other matter pertaining to your new Borla Performance Exhaust System, please give us a call at the number provided on the warranty card.

Minimum Required Tool List:

TOOLS:

1. 3/8" drive ratchet
2. 3/8" drive extension 3"
3. 15mm deep well socket
4. 13mm socket
5. Pry bar

SHOP SUPPLIES:

1. Spray lubricant

Borla Performance - Bill of Materials

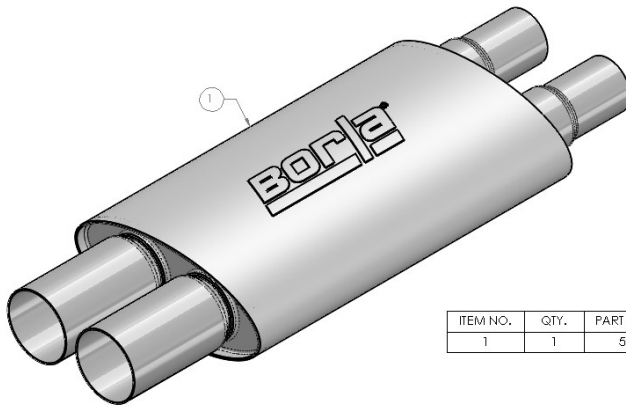

60661

ITEM NO.	QTY.	PART NUMBER	DESCRIPTION
1	1	56735	MUFFLER ASSEMBLY

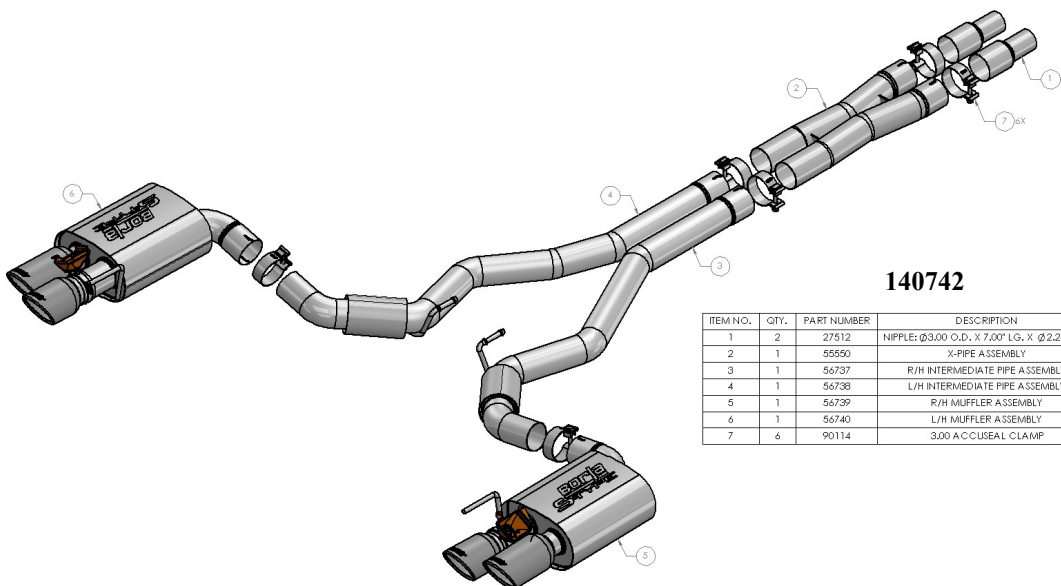

140742

ITEM NO.	QTY.	PART NUMBER	DESCRIPTION
1	2	27512	NIPPLE: Ø3.00 O.D. X 7.00" LG. X Ø2.25 O.D.
2	1	55550	X-PIPE ASSEMBLY
3	1	56737	R/H INTERMEDIATE PIPE ASSEMBLY
4	1	56738	L/H INTERMEDIATE PIPE ASSEMBLY
5	1	56739	R/H MUFFLER ASSEMBLY
6	1	56740	L/H MUFFLER ASSEMBLY
7	6	90114	3.00" ACCUSEAL CLAMP

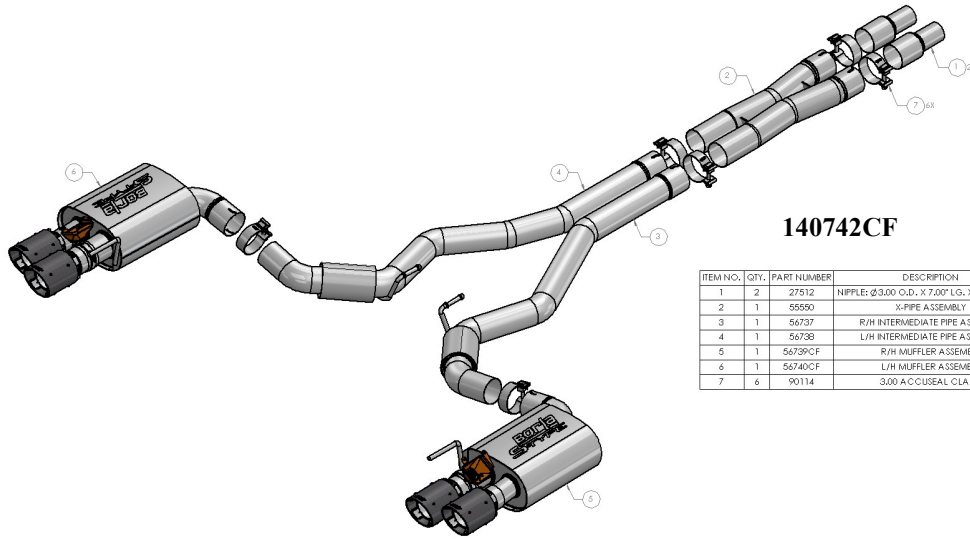

140742CF

ITEM NO.	QTY.	PART NUMBER	DESCRIPTION
1	2	27512	NIPPLE: $\varnothing 3.00$ O.D. X 7.00" LG. X $\varnothing 2.25$ O.D.
2	1	55550	X-PIPE ASSEMBLY
3	1	56737	R/H INTERMEDIATE PIPE ASSEMBLY
4	1	56738	L/H INTERMEDIATE PIPE ASSEMBLY
5	1	56739CF	R/H MUFFLER ASSEMBLY
6	1	56740CF	L/H MUFFLER ASSEMBLY
7	6	90114	3.00 ACCUSEAL CLAMP

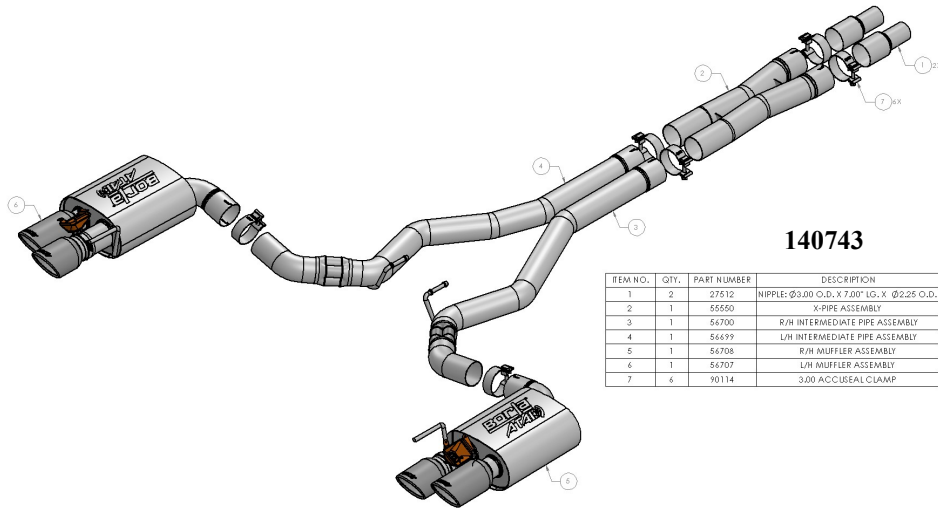

140743

ITEM NO.	QTY.	PART NUMBER	DESCRIPTION
1	2	27512	NIPPLE: $\varnothing 3.00$ O.D. X 7.00" LG. X $\varnothing 2.25$ O.D.
2	1	55550	X-PIPE ASSEMBLY
3	1	56700	R/H INTERMEDIATE PIPE ASSEMBLY
4	1	56699	L/H INTERMEDIATE PIPE ASSEMBLY
5	1	56708	R/H MUFFLER ASSEMBLY
6	1	56707	L/H MUFFLER ASSEMBLY
7	6	90114	3.00 ACCUSEAL CLAMP

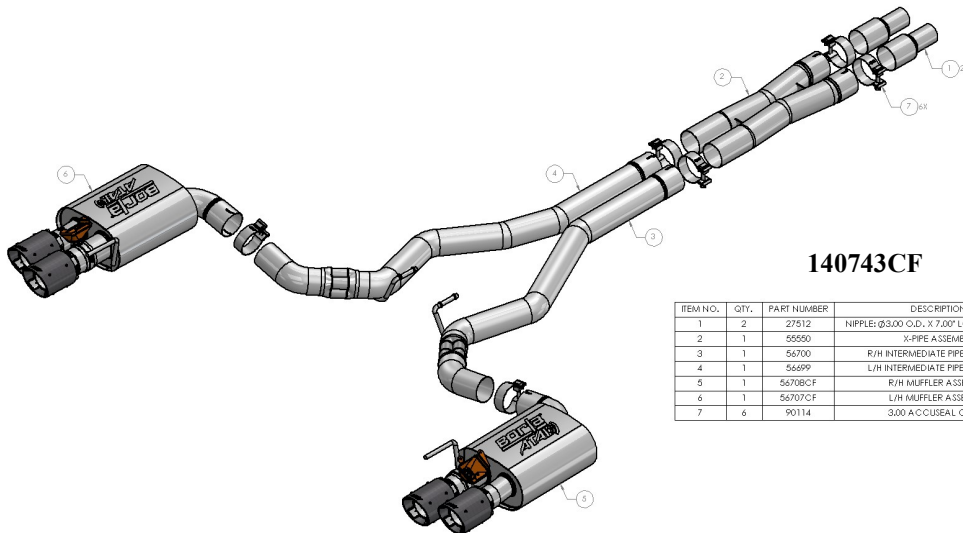

140743CF

ITEM NO.	QTY.	PART NUMBER	DESCRIPTION
1	2	27512	NIPPLE: $\varnothing 3.00$ O.D. X 7.00" LG. X $\varnothing 2.25$ O.D.
2	1	55550	X-PIPE ASSEMBLY
3	1	56700	R/H INTERMEDIATE PIPE ASSEMBLY
4	1	56699	L/H INTERMEDIATE PIPE ASSEMBLY
5	1	56708CF	R/H MUFFLER ASSEMBLY
6	1	56707CF	L/H MUFFLER ASSEMBLY
7	6	90114	3.00 ACCUSEAL CLAMP

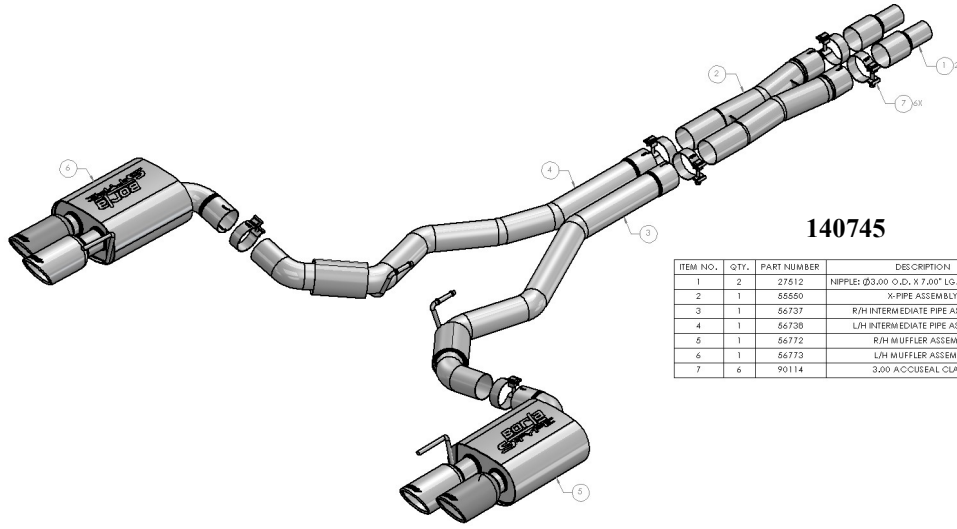

140745

ITEM NO.	QTY.	PART NUMBER	DESCRIPTION
1	2	27512	NIPPLE: Ø3.00 O.D. X 7.00" LG. X Ø2.25 O.D.
2	1	55550	X-PIPE ASSEMBLY
3	1	56737	R/H INTERMEDIATE PIPE ASSEMBLY
4	1	56738	L/H INTERMEDIATE PIPE ASSEMBLY
5	1	56772	R/H MUFFLER ASSEMBLY
6	1	56773	L/H MUFFLER ASSEMBLY
7	6	90114	3.00 ACCUSEAL CLAMP

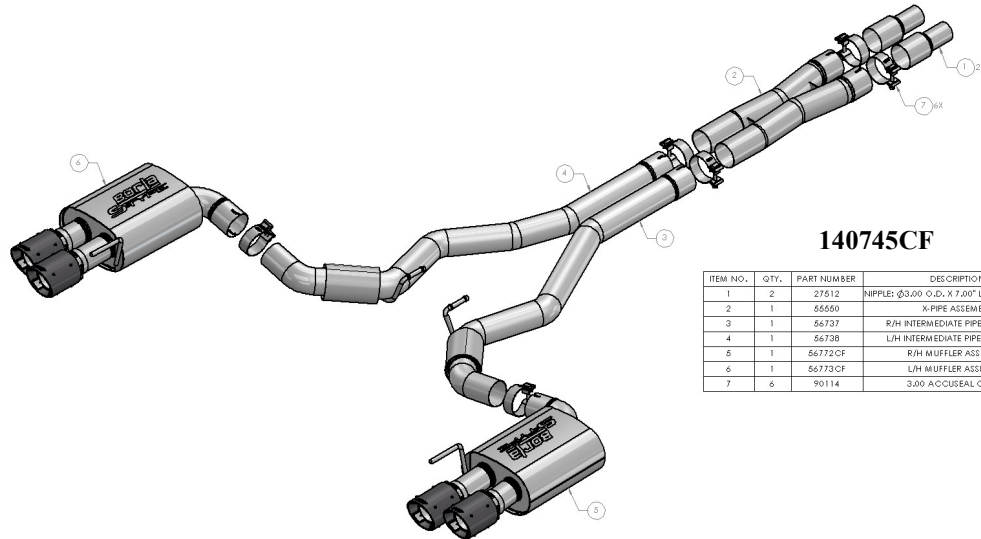

140745CF

ITEM NO.	QTY.	PART NUMBER	DESCRIPTION
1	2	27512	NIPPLE: Ø3.00 O.D. X 7.00" LG. X Ø2.25 O.D.
2	1	55550	X-PIPE ASSEMBLY
3	1	56737	R/H INTERMEDIATE PIPE ASSEMBLY
4	1	56738	L/H INTERMEDIATE PIPE ASSEMBLY
5	1	56772CF	R/H MUFFLER ASSEMBLY
6	1	56773CF	L/H MUFFLER ASSEMBLY
7	6	90114	3.00 ACCUSEAL CLAMP

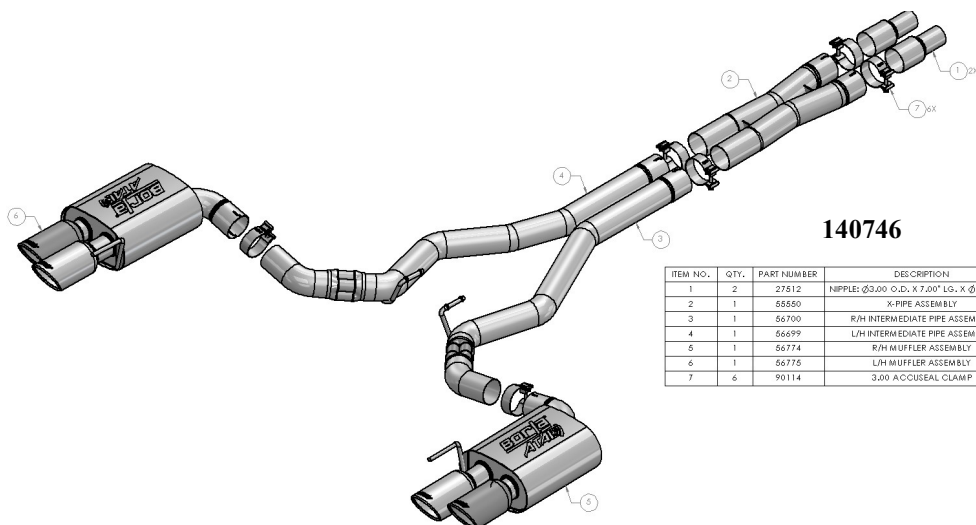

140746

ITEM NO.	QTY.	PART NUMBER	DESCRIPTION
1	2	27512	NIPPLE: Ø3.00 O.D. X 7.00" LG. X Ø2.25 O.D.
2	1	55550	X-PIPE ASSEMBLY
3	1	56700	R/H INTERMEDIATE PIPE ASSEMBLY
4	1	56699	L/H INTERMEDIATE PIPE ASSEMBLY
5	1	56774	R/H MUFFLER ASSEMBLY
6	1	56775	L/H MUFFLER ASSEMBLY
7	6	90114	3.00 ACCUSEAL CLAMP

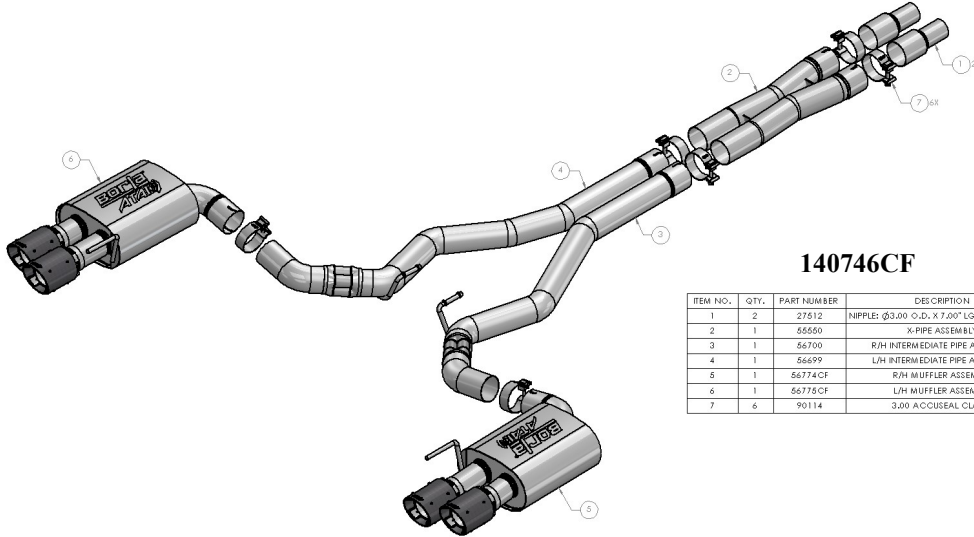

140746CF

ITEM NO.	QTY.	PART NUMBER	DESCRIPTION
1	2	27612	NIPPLE: Ø3.00 O.D. X 7.007 L.G. X Ø2.28 O.D.
2	1	55550	X-PIPE ASSEMBLY
3	1	56700	R/H INTERMEDIATE PIPE ASSEMBLY
4	1	56699	L/H INTERMEDIATE PIPE ASSEMBLY
5	1	56774CF	R/H MUFFLER ASSEMBLY
6	1	56775CF	L/H MUFFLER ASSEMBLY
7	6	90114	3.00 ACCUSEAL CLAMP

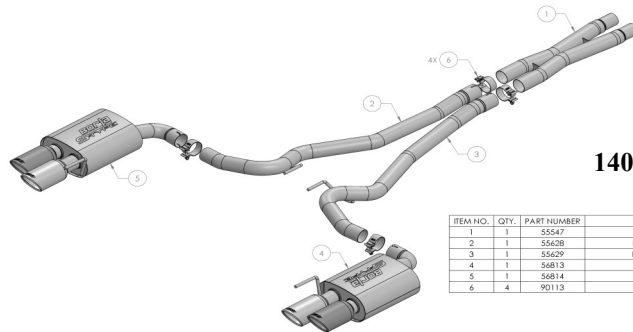

140807

ITEM NO.	QTY.	PART NUMBER	DESCRIPTION
1	1	55547	X-PIPE ASSEMBLY
2	1	55620	L/H OVER-AXLE PIPE ASSEMBLY
3	1	55629	R/H OVER-AXLE PIPE ASSEMBLY
4	1	56813	R/H MUFFLER ASSEMBLY
5	1	56814	L/H MUFFLER ASSEMBLY
6	4	90113	S/S ACCUSEAL CLAMP Ø2.50

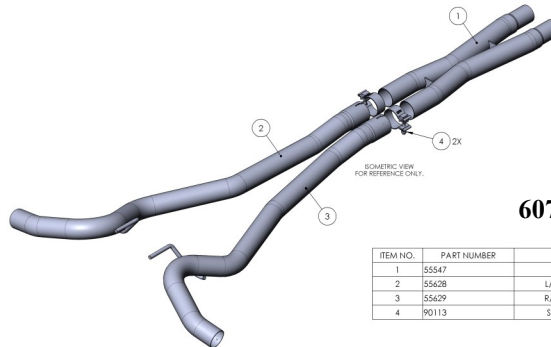

60705

ITEM NO.	PART NUMBER	DESCRIPTION	QTY.
1	55547	X-PIPE ASSEMBLY	1
2	55628	L/H OVER-AXLE PIPE ASSEMBLY	1
3	55629	R/H OVER-AXLE PIPE ASSEMBLY	1
4	90113	S/S ACCUSEAL CLAMP Ø2.50	2

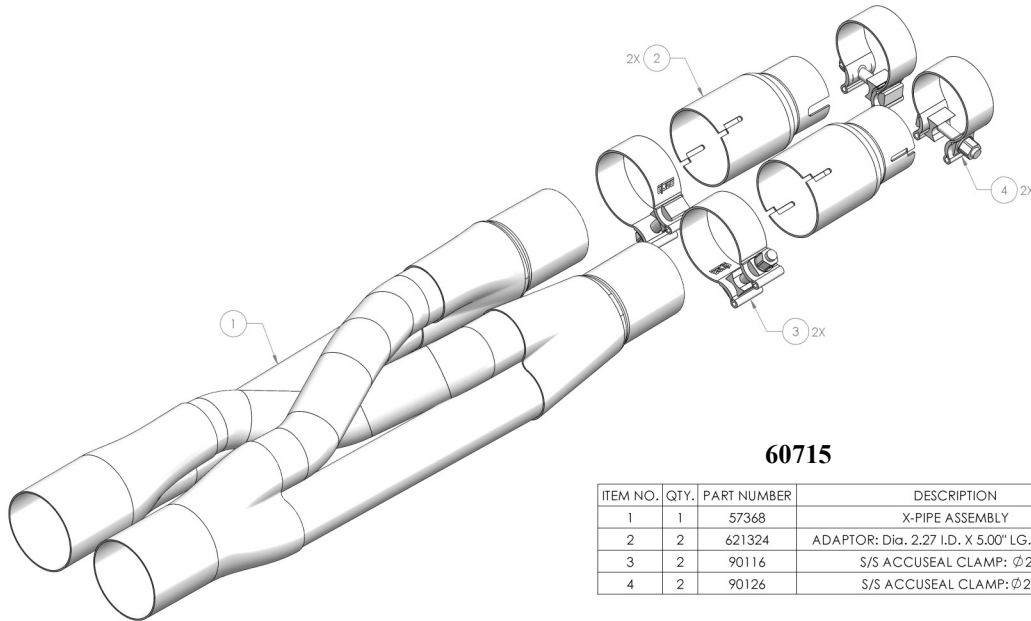

60715

ITEM NO.	QTY.	PART NUMBER	DESCRIPTION
1	1	57368	X-PIPE ASSEMBLY
2	2	621324	ADAPTOR: Dia. 2.27 I.D. X 5.00" LG. X 2.78 I.D.
3	2	90116	S/S ACCUSEAL CLAMP: Ø2.75
4	2	90126	S/S ACCUSEAL CLAMP: Ø2.38

Caution!!! *Never work on a hot exhaust system. Serious injury in the form of burns can result if the vehicle has been in use and the exhaust system is hot, allow vehicle to cool for at least 1 hour. Always wear eye protection when working under any vehicle.*

Note: *It is our recommendation that you use a hoist or hydraulic lift to facilitate the installation of your new Borla Performance Exhaust System.*

Taking all under car safety precautions, lift the vehicle using a hoist or hydraulic lift. Once this has been done, you may begin the removal of your old exhaust system from your vehicle.

Note: *Before removing the original exhaust system from your vehicle, please compare the parts you have received with the bill of materials provided on the previous page to assure that you have all the parts necessary for the installation of your new Borla Performance Exhaust System.*

Note: *With a used vehicle, we suggest a penetrating spray lubricant to be applied liberally to all exhaust fasteners and allowing a significant period of time for the chemical to lubricate the threads before attempting to disassemble.*

Original Exhaust System Removal

1. Disconnect left and right side wire harness by pulling pin and sliding out from electrical Assembly. (See Fig. 1)
2. Beginning on the vehicle left-side, using a flat blade screwdriver pull the clip to disengage it from the pipe. (See Fig. 2)
3. REPEAT STEP 2 for the vehicle right-side. Loosen the 4 clamp fasteners and retain the original clamps for re-installation.
4. Loosen (2) factory bolts on both rear left-side and right-side rubber brackets. Leave rubber isolator assemblies on the muffler hangers. (See Fig. 3)
5. Using a muffler stand or an additional person hold the muffler assembly in position, and carefully remove from vehicle.
6. Factory exhaust system removed. (See Fig. 5)

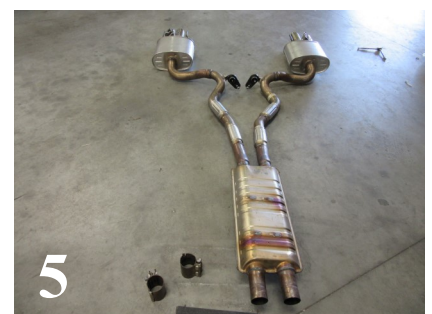
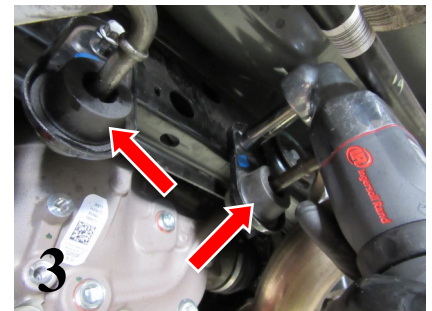
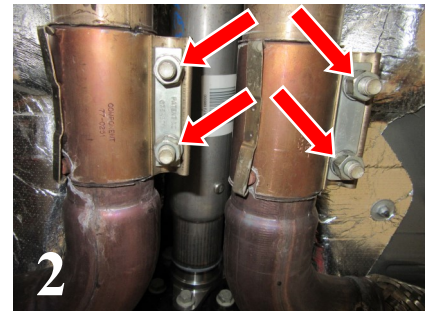

Borla Performance Cat-Back™ Exhaust System Installation

1. Orient components on floor referencing drawing on pages 2 - 6.
2. Transfer both rubber isolators from factory exhaust to the **Intermediate Pipes** noting the correct orientation. (See Fig. 6)
3. Slide the adapter pipes into the **X-Pipe Assembly** using two 3" clamps and fasten the components together. (See Fig. 7)
4. SWITCHFIRE X-PIPE UPGRADE INSTALLATION: Slide a clamp over each outlet side of the **Adaptor** and insert onto the **X-Pipe Assembly**. Slide a clamp over each outlet on the vehicle and install the **Adaptor and X-Pipe Assembly** onto the vehicle. Do not tighten the clamp bolts.
5. RESONATOR OPTION INSTALLATION: Install the factory band clamps onto the front pipes and insert the inlets of the **Resonator Option** into the band clamps. (See Fig. 8) Do not tighten the clamp bolts.
5. Install the **R/H Intermediate Pipe Assembly** inserting the hanger hook into the rubber isolator. (See Fig. 9)
6. REPEAT STEP 5 for the **L/H Intermediate Pipe Assembly**.



WARNING: Use extreme caution during installation. Torque all fasteners according to manufacturer's torque values and tightening sequence. **DO NOT** use air impact tools to tighten fasteners on Borla Performance Exhaust Systems. Use of such tools may result in bent flanges or gasket contact areas leading to exhaust leaks.

NOTE: When you first start your vehicle after the installation of your new Borla Performance Exhaust System, there may be some smoke and fumes coming from the system. This is a protective oil based coating used in the manufacturing of mandrel bent performance exhaust tubing. This is not a problem and will disappear within a very short period of time after the exhaust has reached normal operating temperatures.

Borla Performance Cat-Back™ PNs-140742, 140743 ONLY Exhaust System Installation (Cont'd)

NOTE: The Actuator Gear on electronic actuator needs to be aligned to the Valve Slot for proper engagement. Improper function of the valves, a CEL, or damage can occur if these aren't aligned.

- A. Valve Plate needs to be in open position (please rotate valve prior to mounting Factory Actuator to **R/H Muffler Assembly**). (See Fig. 10)
- B. Orient the Actuator Gear to the valve Slot then position Factory Actuator bolt holes. Reuse (3) factory bolt/washer/nut assemblies in securing the Factory Actuator to the **Muffler Assembly**. (See Figs. B, C, D)
- C. Verify alignment of Actuator Gear to the valve Slot. Tighten the nut/bolt assemblies 8-9 ft. lb. torque. (See Fig. E)
- D. REPEAT STEPS A, B, & C for the **L/H Muffler Assembly** factory actuator installation.
- E. **Reconnect Wire Harness to Factory Actuators, both left and right sides.**

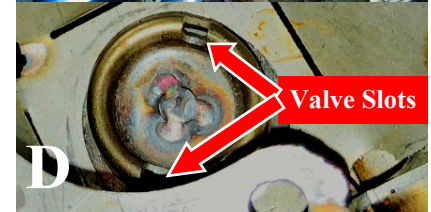
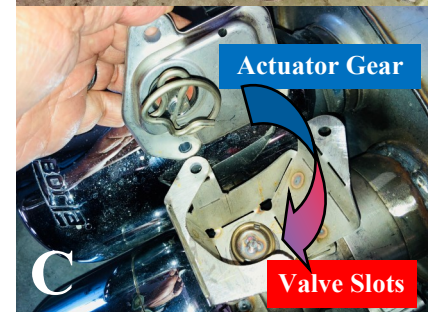
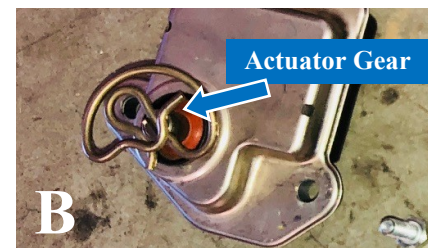
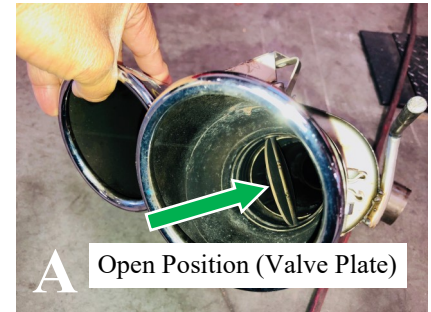

WARNING: Use extreme caution during installation. Torque all fasteners according to manufacturer's torque values and tightening sequence. **DO NOT** use air impact tools to tighten fasteners on Borla Performance Exhaust Systems. Use of such tools may result in bent flanges or gasket contact areas leading to exhaust leaks.

NOTE: When you first start your vehicle after the installation of your new Borla Performance Exhaust System, there may be some smoke and fumes coming from the system. This is a protective oil based coating used in the manufacturing of mandrel bent performance exhaust tubing. This is not a problem and will disappear within a very short period of time after the exhaust has reached normal operating temperatures.

Borla Performance Cat-Back™ Exhaust System Installation (Cont'd)

7. Starting on the vehicle left-side, place a clamp on the **R/H Muffler Assembly** inlet pipe and inserting the inlet pipe into the **R/H Intermediate Pipe Assembly**. Insert the hanger into the rear rubber isolator. (See Fig. 10) Do not tighten the clamps.
8. REPEAT STEP 5 for the vehicle **L/H Muffler Assembly**. Do not tighten the clamps.
9. Check your exhaust system for proper clearance under the vehicle and also for tip alignment. (See Fig. 11)
10. Starting at front flanges and moving to rear of vehicle, tighten flange hardware bolts. Orient position of bolt (on supplied clamps) between (not over) pipe notches and tighten to 35 ft. lbs. torque. (See Fig. 12)
11. Before starting your vehicle, make sure to check all wires, hoses, brake lines, body parts and tires for safe clearance from the exhaust system.
12. Start vehicle and check for any leaks. If any leaks are found, determine cause (such as loose or incorrectly positioned clamp) and repair as necessary.

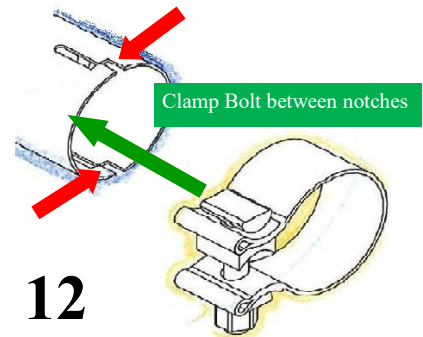

WARNING: Use extreme caution during installation. Torque all fasteners according to manufacturer's torque values and tightening sequence. **DO NOT** use air impact tools to tighten fasteners on Borla Performance Exhaust Systems. Use of such tools may result in bent flanges or gasket contact areas leading to exhaust leaks.

NOTE: When you first start your vehicle after the installation of your new Borla Performance Exhaust System, there may be some smoke and fumes coming from the system. This is a protective oil based coating used in the manufacturing of mandrel bent performance exhaust tubing. This is not a problem and will disappear within a very short period of time after the exhaust has reached normal operating temperatures.