

FITTING INSTRUCTIONS

BP5190006L & BP5190006R TOYOTA TACOMA 05 ON FRONT

WARNING

- ◆ This product must be installed exactly as per these instructions using only the hardware supplied.
- ◆ In the event of damage to any suspension component, contact your nearest authorised ARB stockist. Repairs or modifications to the suspension system components must not be attempted.
- ◆ Do not use this product for any vehicle make or model, other than those specified by ARB.
- ◆ Do not remove labels from suspension components.
- ◆ This product or its fixing must not be modified in any way.
- ◆ The installation of this product may require the use of specialized tools and/or techniques
- ◆ It is recommended that this product is only installed by trained personnel
- ◆ These instructions are correct as at the publication date. ARB Corporation Ltd. cannot be held responsible for the impact of any changes subsequently made by the vehicle manufacturer
- ◆ During installation, it is the duty of the installer to check correct operation/clearances of all components
- ◆ Work safely at all times

Note: These fitting instructions should be read in conjunction with the vehicle workshop manual.

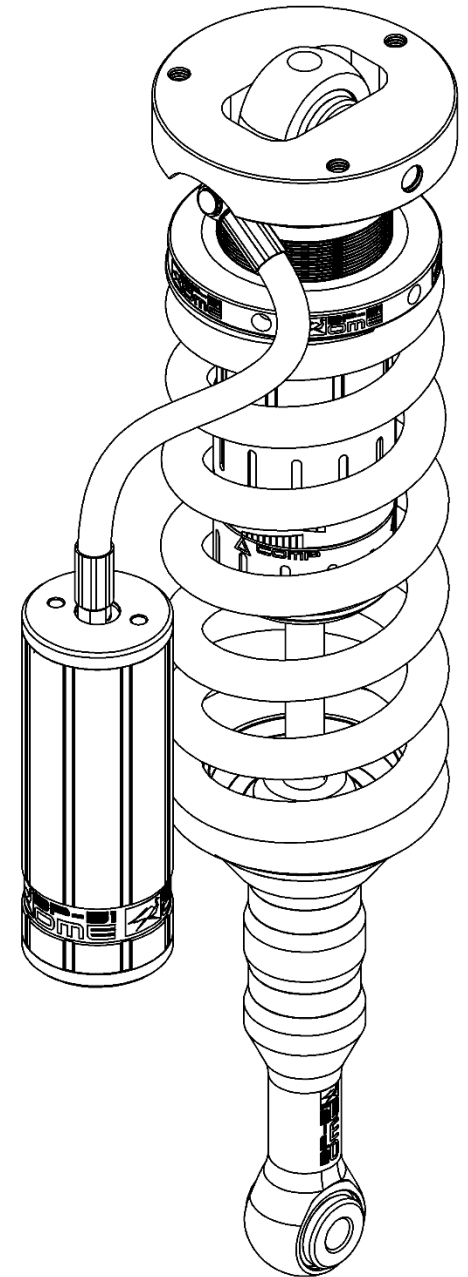

FITTING KIT CONTENTS – VM80010016

Item	Description	Qty.	Part No.
1	RESERVOIR CLAMP	2	VE10010003
2	FRONT RESERVOIR BRACKET RIGHT (SHOWN)	1	VE10020016L
	FRONT RESERVOIR BRACKET LEFT	1	VE10020016R
3	HOSE BRACKET	1	VF60050009
4	ADJUSTER TOOL	1	VC10010071
5	TACOMA FASTENER KIT FRONT	1	VM60010007
	5.1 M10 X 1.5 X 30MM BOLT KIT	6	6151555
	5.2 M6 X 16MM BOLT	4	VD60030003
	5.3 M6 FLAT WASHER	4	VE70020005
	5.4 M6 NYLOCK NUT	4	VD60010003
	5.5 M8 X 1.25 X 20MM BOLT	1	VD60030001
	5.6 M8 FLAT WASHER	2	VE70020004
	5.7 M8 NULOCK NUT	1	VD60010004

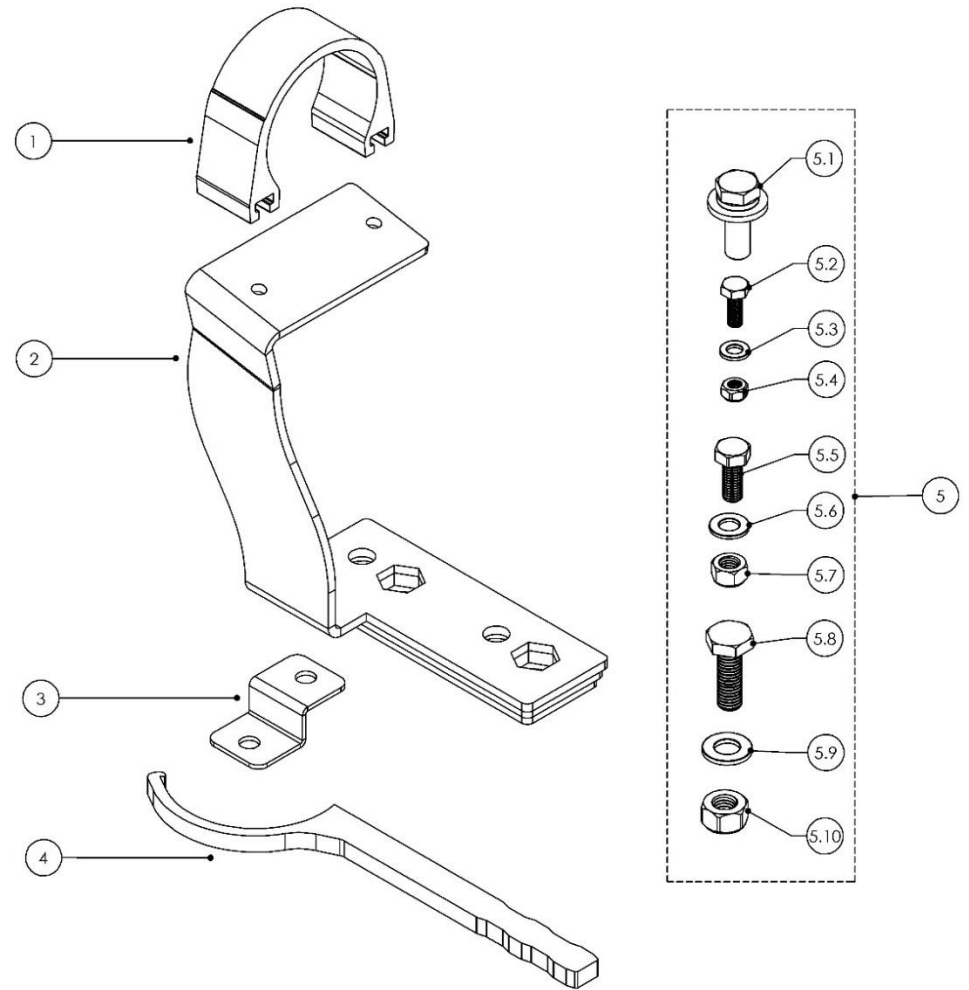

DAMPER PREPARATION

Before fitment the spring preload may need to be adjusted to suit your front accessory fitment and desired ride height.

Use workshop tool kit VM80020001 to aid spring adjustment.

The preload is set at the factory to 20mm as shown by the diagram. This aims to achieve around 50mm increase in ride height over OE when a Bull Bar and winch are fitted.

It is required to set the preload before the strut assembly is fitted to the vehicle. Use a spring compressor to compress the spring, loosen the pinch bolt on the preload ring and adjust to the desired setting. Tighten the pinch bolt and remove the strut assembly from the spring compressor.

As a guide, set the preload as specified below to achieve around 50mm (2") increase in ride height.

<u>Front accessories</u>	<u>Preload</u>
Bar & winch	20 mm
Bar only	15 mm
No accessories	10 mm

**Spring preload must only be adjusted when a spring compressor is used to take load off the preload ring.
DO NOT attempt to adjust preload with load on the spring when fitted to the vehicle.**

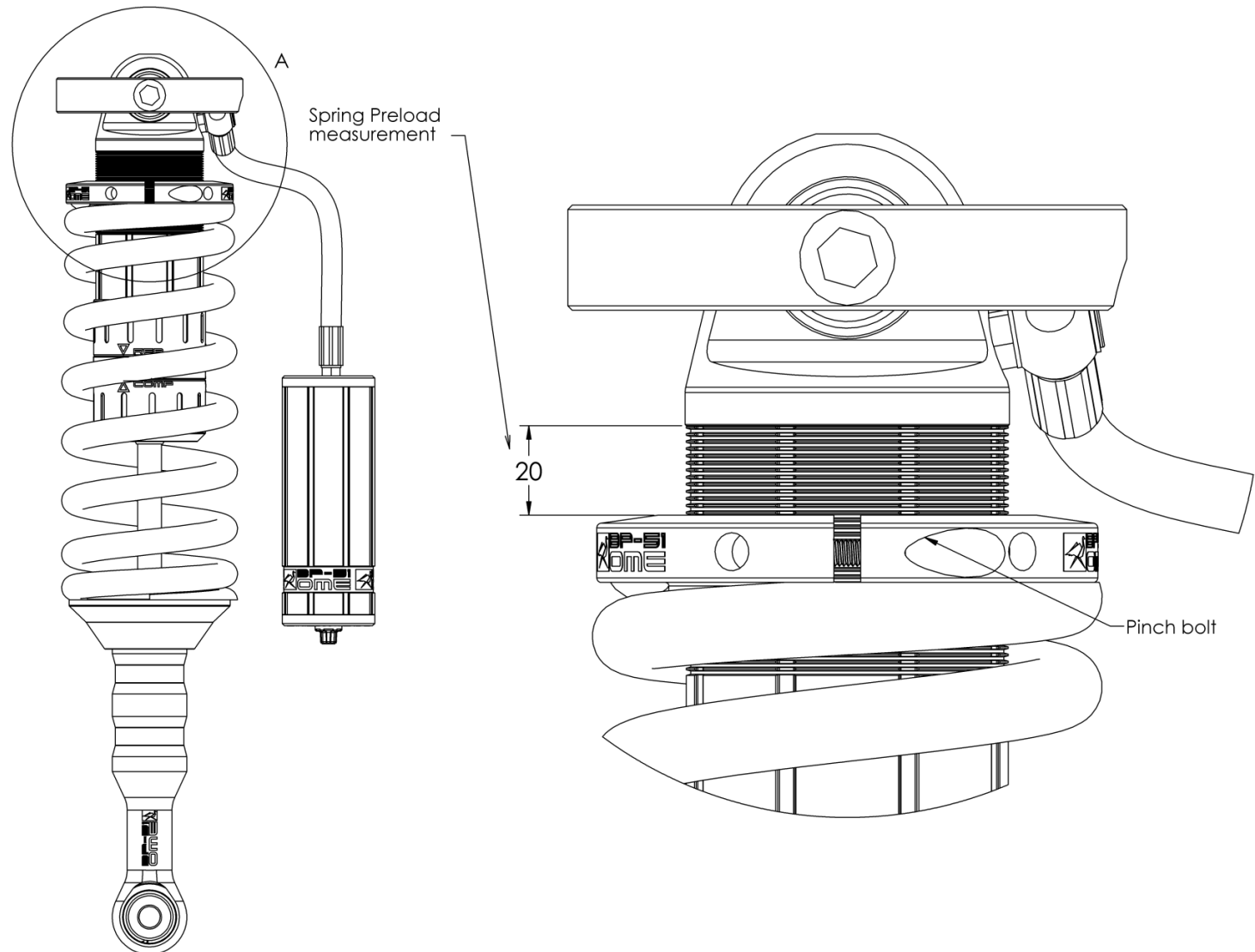

DAMPER MOUNTING SEQUENCE

Remove old dampers from vehicle.

For LH and RH detach sway bar link from spindle (1) and ball joint from steering arm (2) and remove sway bar saddles (3).

To provide good access for inserting the new strut assembly it helps to cable tie the sway bar to the upper arm (4).

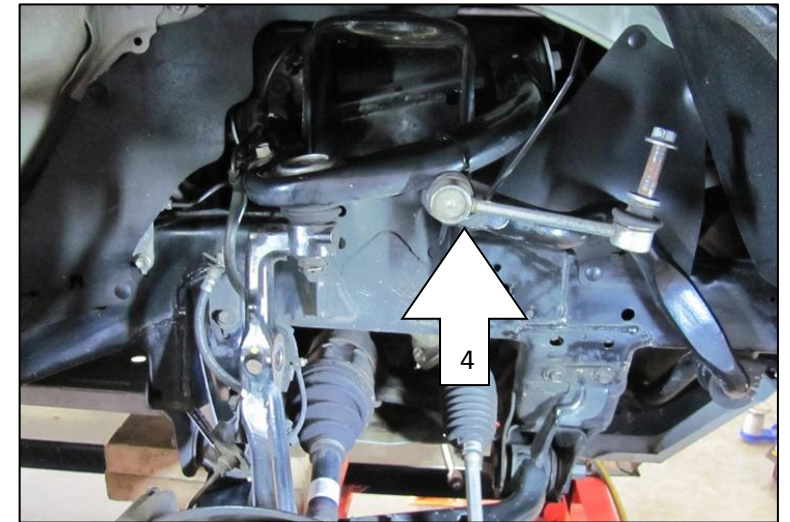
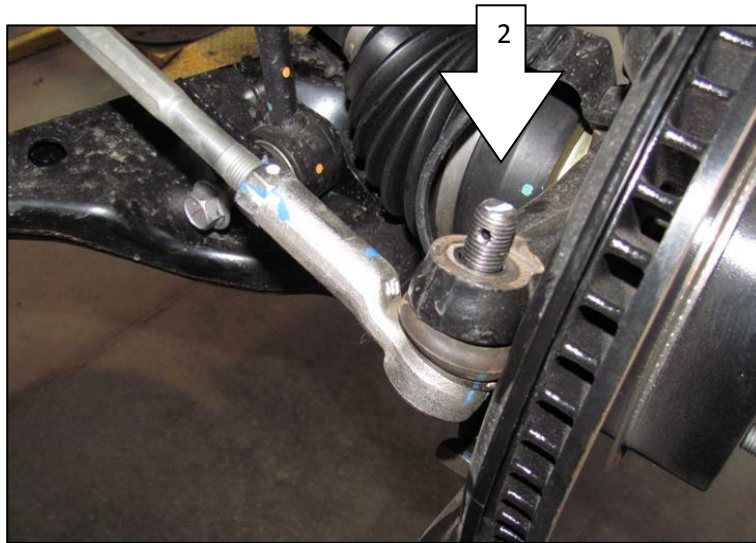
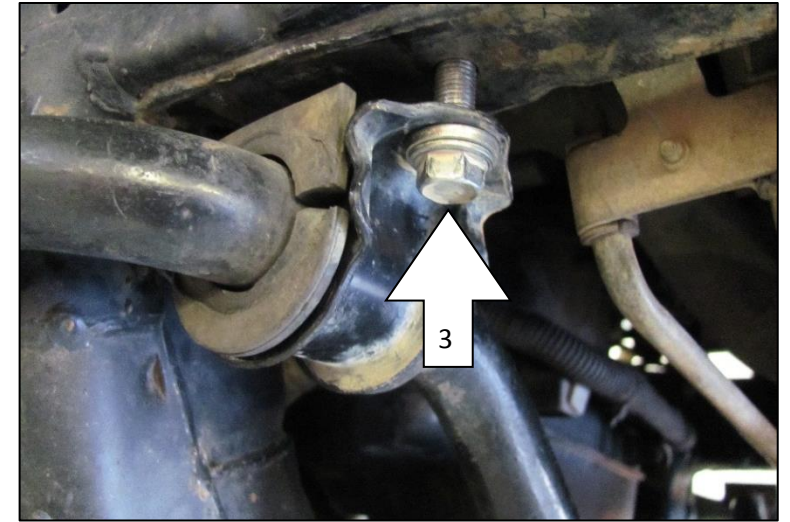
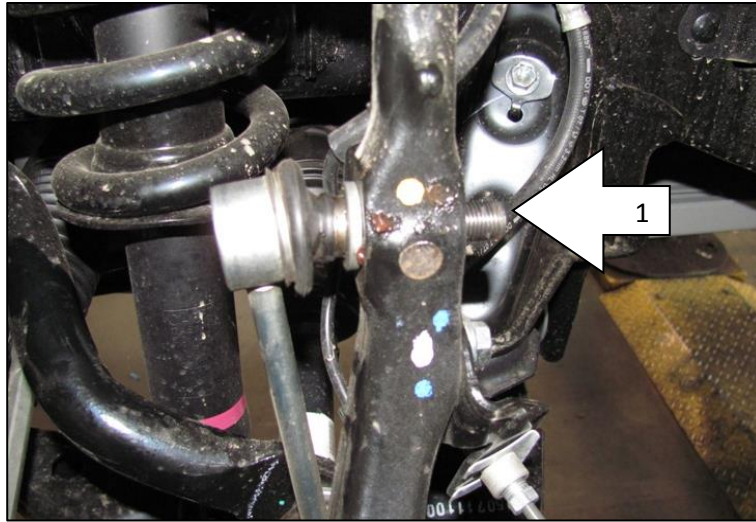

DAMPER MOUNTING SEQUENCE

Left and Right Hand sides are the same with the exception of the way the hose exits the damper. L and R should be etched on the damper part number.

When mounted in the vehicle the hose and reservoir should be towards the front.

Top Mount:

Fit the damper and secure the top mount with bolts and washers finger tight (1).

Lower Mount:

Secure bottom mount using original bolt and nut. (2)
Torque: 108 Nm (70 ft.lbf)

Top Mount:

Fasten top three bolts and bottom bolt securely.
Torque: 40 Nm (32 ft.lbf)

(Right Hand Side Shown)

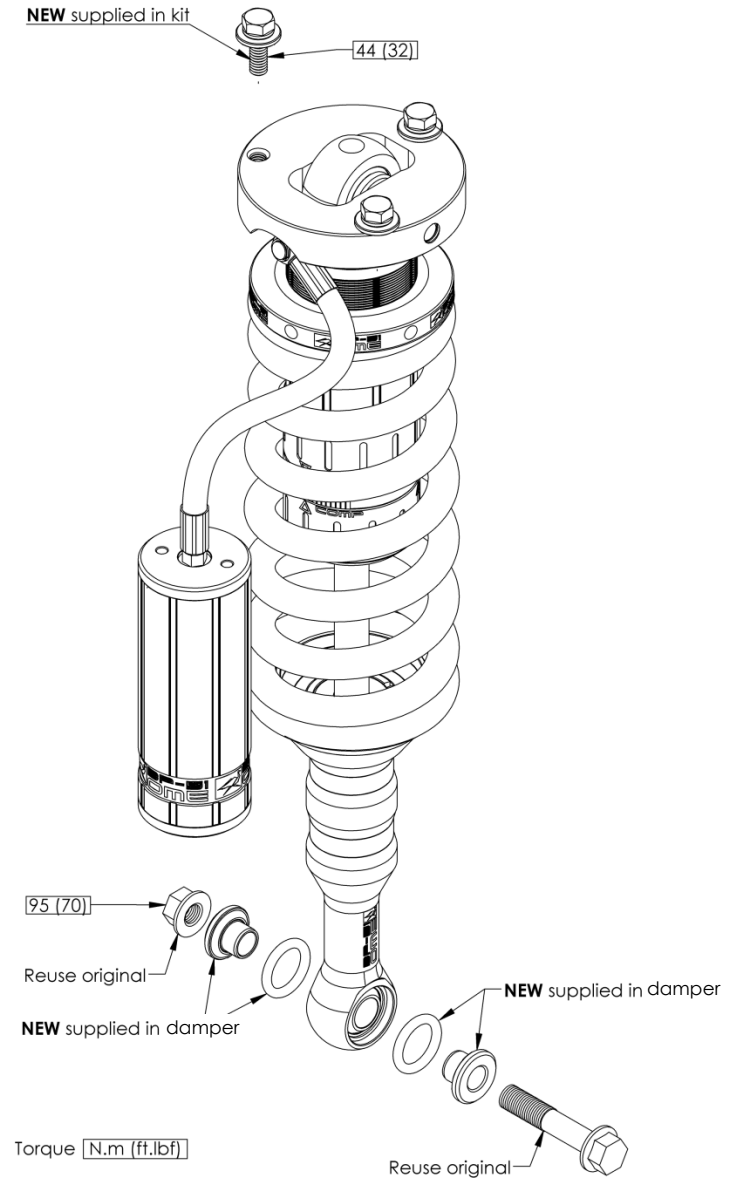

RESERVOIR MOUNTING SEQUENCE

On right hand side (RHS) of vehicle, at the chassis rail forward of the front wheels, locate and pull back the rubber lining to expose the top side of the chassis rail. This is the position where the BP-51 Resi will be mounted.

For 2005 to 2015 models only, on the RHS you will have to re-position a hose mount using bracket VF6005009.

1. Remove original hose bracket bolt from top of chassis (1).
2. Mount VF60050009 bracket to chassis using original bolt, then fix hose bracket to new position using supplied M8 x 20 fasteners supplied.
3. Fit M6 bolts to Resi Mount VE10020016L/R and secure with nyloc nut and flat washer finger tight only.
4. Fit the M10 x 30 bolts (6151232) to the hex cavity in the Mount and secure the Mount to the chassis using the original bolts used to secure the sway bar saddle. Torque to 40 N.m (30ft.lb).

1.

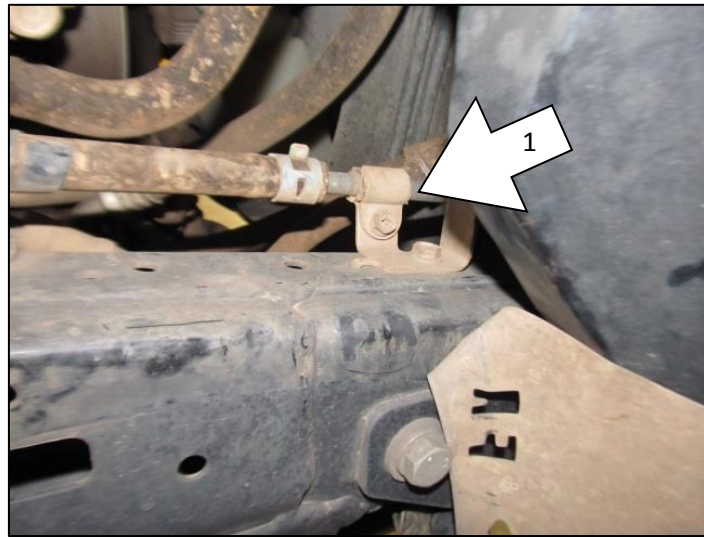

2.

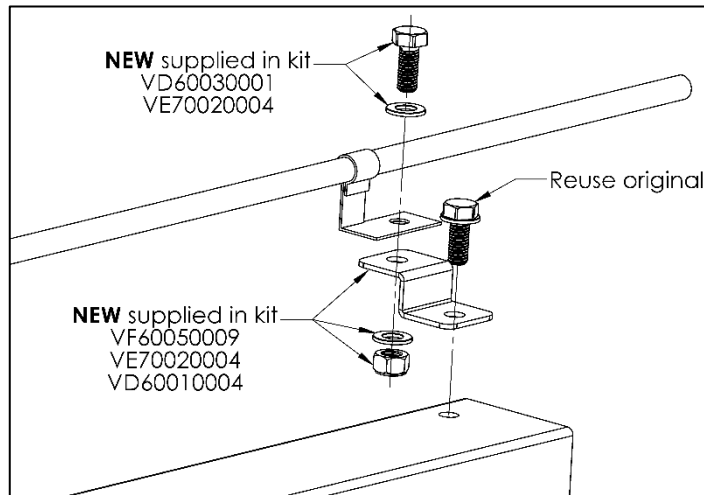

3.

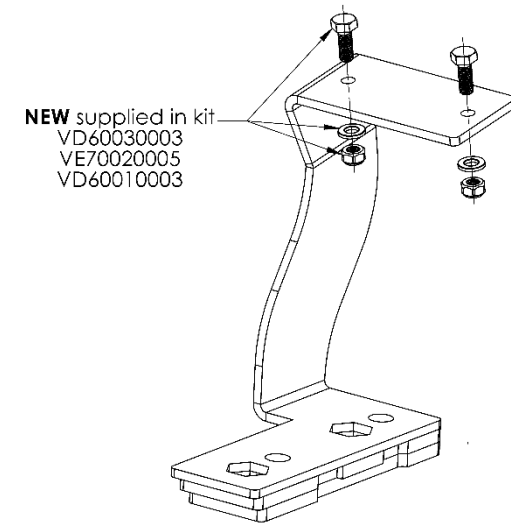

4.

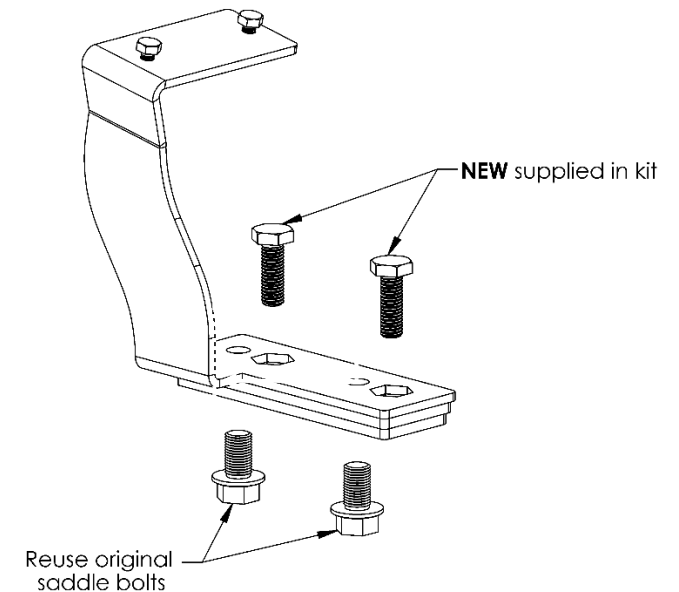

5. Fit the mounting saddle to the reservoir and slide over the heads of the bolts in the Resi Mount.
6. Centralise the saddle on the plate and adjust the position of the reservoir as shown
7. Fit the original sway bar saddle to the bolts protruding from the Resi Mount and secure using flat washers and M10 nuts supplied.

Repeat steps 3 -4 for LHS.

Secure all fasteners.

<u>Fastener</u>	<u>Torque</u> N.m (ft.lb)
Sway bar link to upright	70 (52)
Steering tie rod end to upright	88 (65)
Resi mount to chassis	40 (30)
Strut top hat	44 (32)
Strut to lower control arm	95(70)

5.

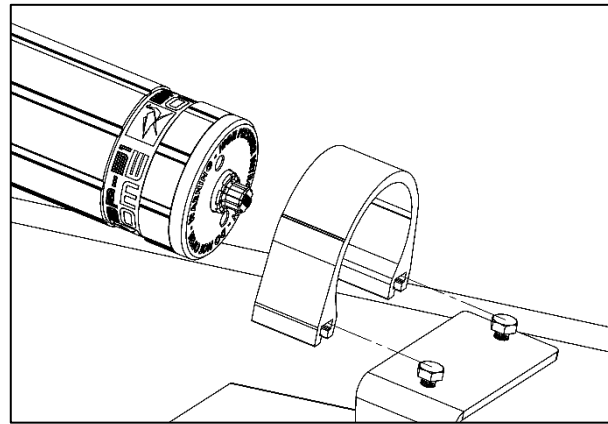

6.

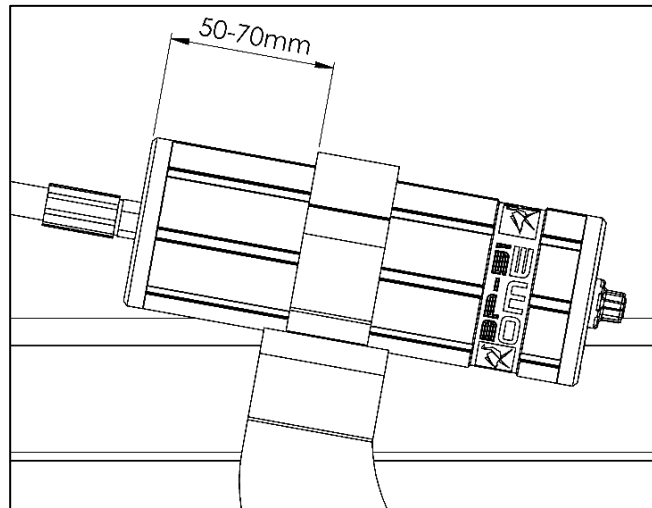

7.

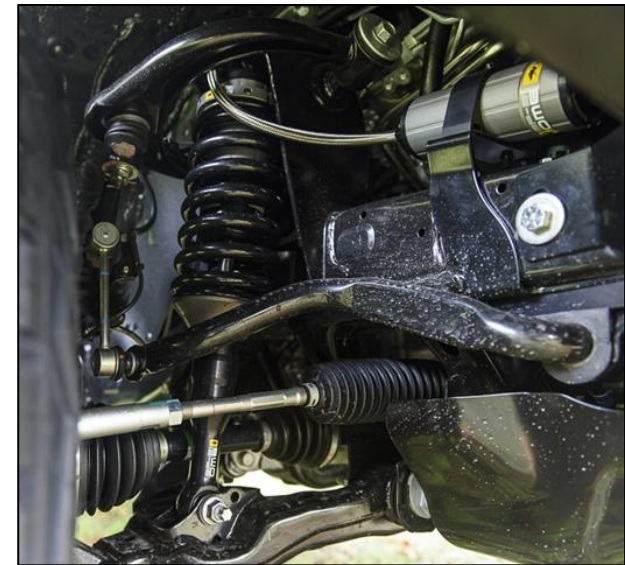
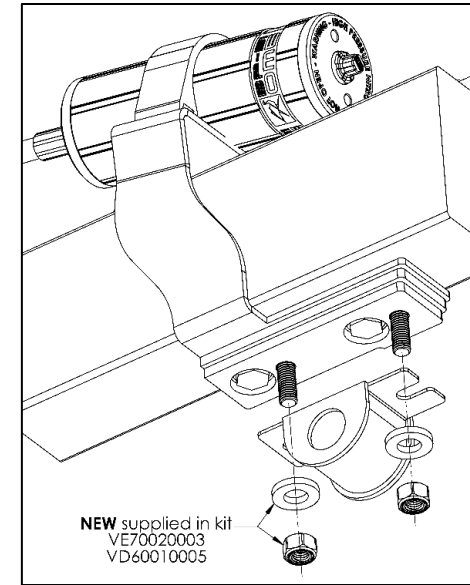

DAMPING ADJUSTMENT

These dampers have been set in the factory to be used for a vehicle with Bull Bar and Winch fitted.

If your accessory fitment differs, use the table below as a guide for recommended Compression and Rebound adjuster settings.

Refer to the Owner's Manual for more information.

Front Accessories	Compression	Rebound
Factory setting	3	6
Bar & winch	4-8	6-10
Bar only	2-6	5-9
No accessories	0-4	4-8

SPECIFICATIONS

- | | | |
|---|-------------------|--------|
| 1 | Extended Length | 545 mm |
| 2 | Compressed Length | 439 mm |

SPARE PARTS

Refer to Service And Parts Manual, section: **BP-51 S&P 3.1-BP5190006L&R**

