

FITTING INSTRUCTIONS

BP5160013/BP5160015

TOYOTA LANDCRUISER 80/105 SERIES REAR

WARNING

- ◆ This product must be installed exactly as per these instructions using only the hardware supplied.
- ◆ In the event of damage to any suspension component, contact your nearest authorised ARB stockist. Repairs or modifications to the suspension system components must not be attempted.
- ◆ Do not use this product for any vehicle make or model, other than those specified by ARB.
- ◆ Do not remove labels from suspension components.
- ◆ This product or its fixing must not be modified in any way.
- ◆ The installation of this product may require the use of specialized tools and/or techniques
- ◆ It is recommended that this product is only installed by trained personnel
- ◆ These instructions are correct as at the publication date. ARB Corporation Ltd. cannot be held responsible for the impact of any changes subsequently made by the vehicle manufacturer
- ◆ During installation, it is the duty of the installer to check correct operation/clearances of all components
- ◆ Work safely at all times

Note: These fitting instructions should be read in conjunction with the vehicle workshop manual.

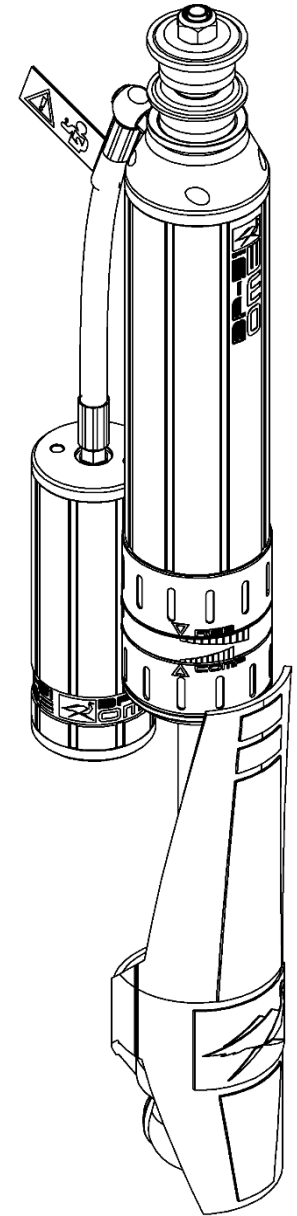

FITTING KIT CONTENTS – VM80010026

Item	Description	Qty.	Spare Part No.
1	BRKT RESI: LC80/105 REAR	1	VE10020031RSP
		1	VE10020031LSP
2	FASTENER: NUT: M6 NYLOC	4	VD60010003SP
3	WASHER: M6 BLACK	4	VE70020005SP
4	FASTENER: BOLT: M6x 1.0x 16	4	VD60030003SP
5	MOUNT: RESERVOIR CLAMP	2	VE10010003SP
6	WASHER: ID19 OD46 T2	4	VE70020006SP
7	WASHER: ID20 OD32 T6	2	VE70020008SP
8	WASHER: SPACER (12x19x3mm)	6	VE70020001SP
9	TOOL: ADJUSTER TOOL	1	VC10010071SP

SUPPLIED WITH BP-51 DAMPER

PIN MOUNT BUSH KIT (Spare Part No. VM50010005SP)

Item	Description	Qty.	Part No.
A	M12 NUT NYLOC	1	VD60010002
B	WASHER LOCATING 195002	1	VF60020005
C	WASHER RETAINING 195004	2	VF60020006
D	BUSH NR 143820	2	VD50030004

SUPPLIED WITH BP-51 DAMPER

SHAFT GUARD RETAINERS (Spare Part No. VD31000003SP)

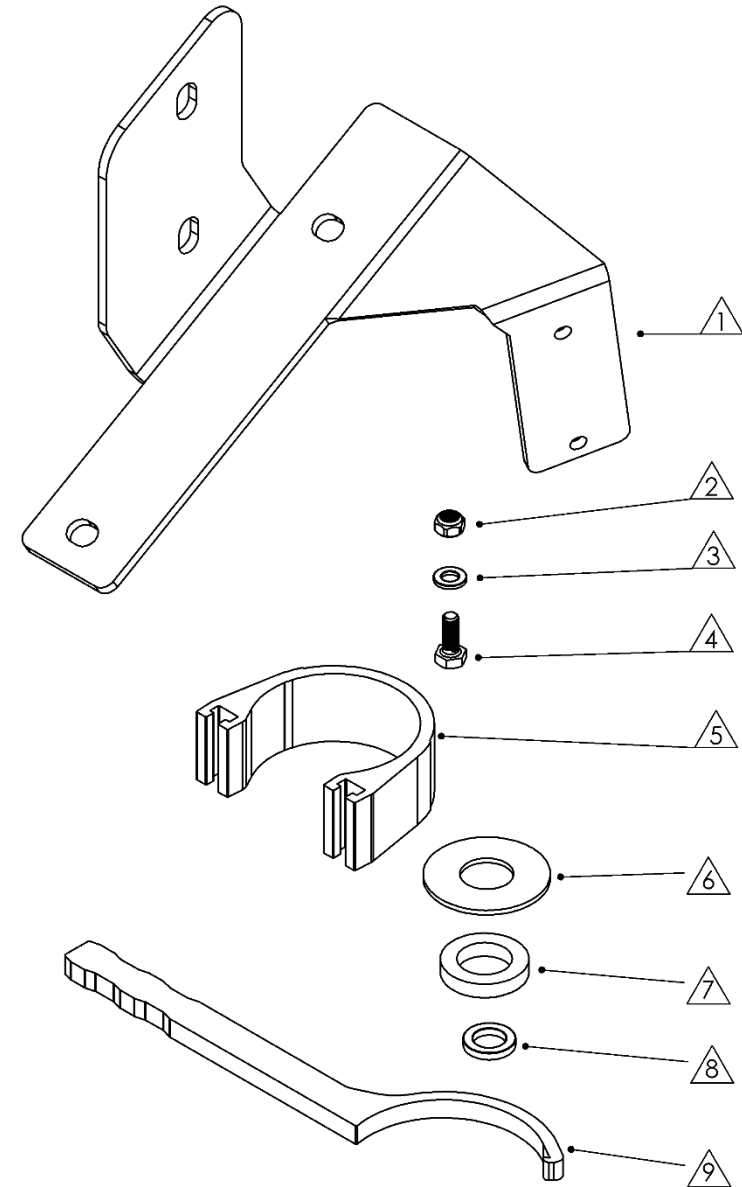
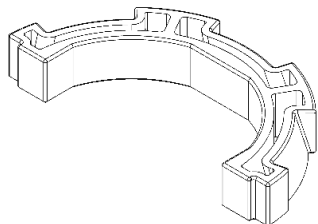

DAMPER PREPARATION

Remove the OE shocks from the vehicle.

The new BP-51 needs to be prepared with mounting components before it is fitted to the vehicle.

Left and Right are the same.

Refer to the next step for mounting the damper to the vehicle.

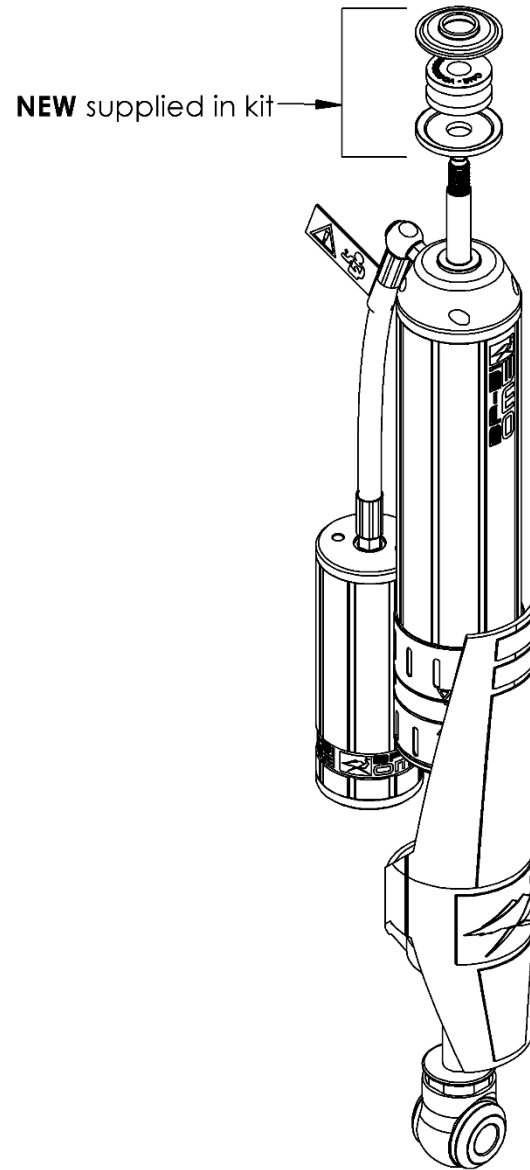

Top Mount

First fit the retaining washer, bush and then locating washer to the pin.

Bottom Mount

Slide the guard and clamp assembly up off the eyelet so that the bottom mount can be accessed.

DAMPER MOUNTING SEQUENCE

The BP-51 needs to be fitted with the suspension in droop.

Disconnect the sway bar and then remove the sway bar link brackets from the vehicle.

NEW supplied in kit
VF50010005

NEW supplied in kit
VE70020008

NEW supplied in kit
VE70020006

NEW supplied in kit
VE70020001

Re use
original

Top Mount

Fit the damper to the vehicle top mount first.
Now fit the bush and retaining washer, securing with the nut as shown by the diagram. Leave finger tight and tighten once the bottom eye is mounted and secured.

Fit the top mount such that the hose fitting leaving the damper is pointing inboard slightly towards the back of the vehicle.



n
Ensure the new 6mm flat retaining washer (VE70020008) is in place then slide the guard up, fit the damper and secure with the new and original hardware as shown.

Fit the two shaft guard retainers to the eyelet and secure by firmly pulling the guard down over the retainers. Refer to next page for more detail

SECURING SHAFT GUARDS

The shaft guards need to be secured after the dampers are fitted to the vehicle.

Fit the two retainers to the eyelet as shown.

There are features on the shaft guard that locate in the gap between the two retainers. Align the guard with these gaps and firmly pull down over the retainers to secure in place.

IMPORTANT!

Check Retainers are completely secured by guard. Use a flat blade screwdriver to poke retainer under tab on guard if required. Failure to do so will result in dirt shield coming loose.

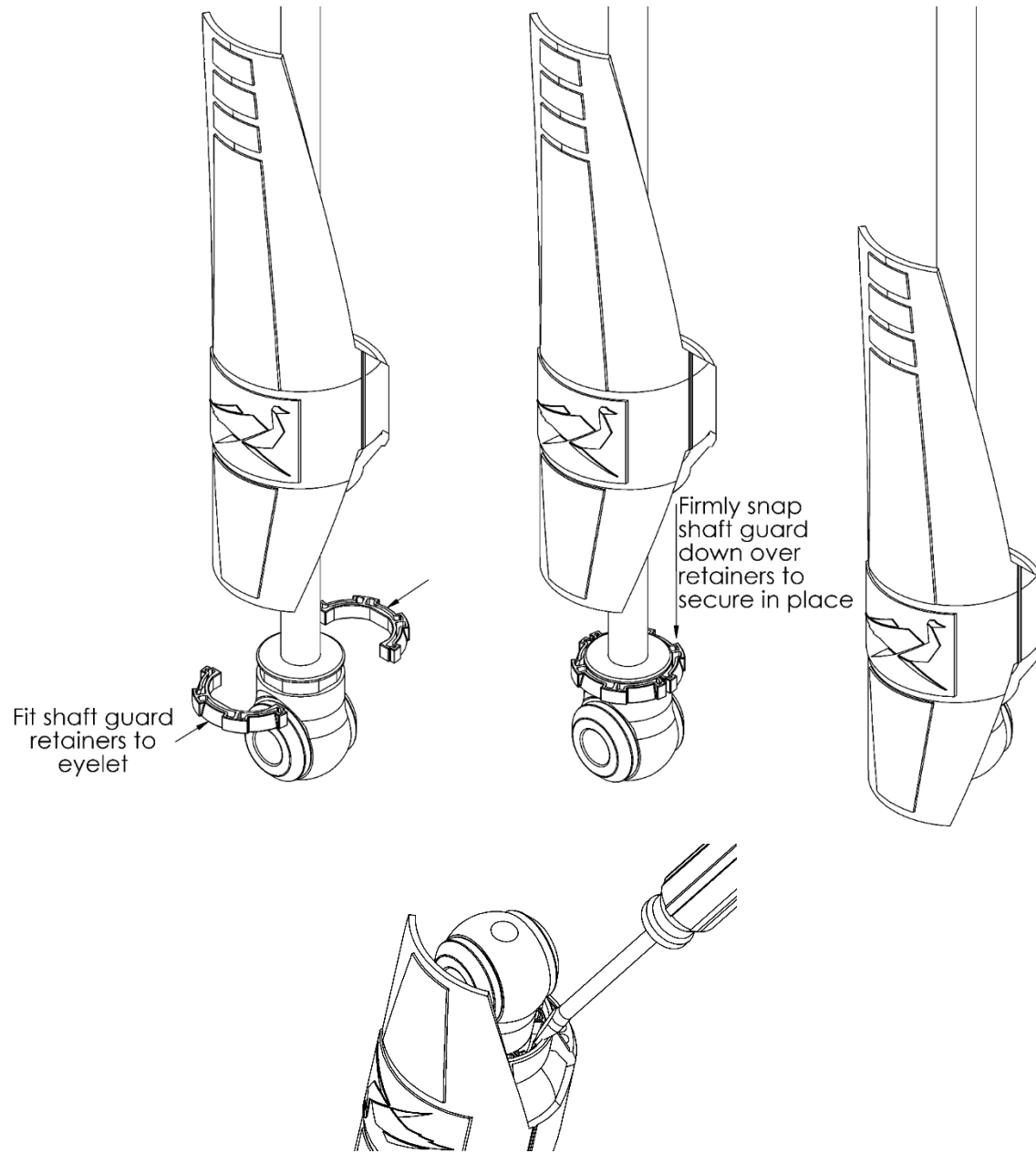

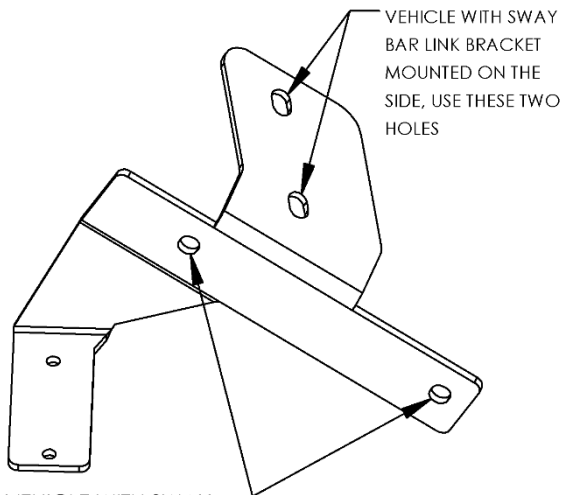
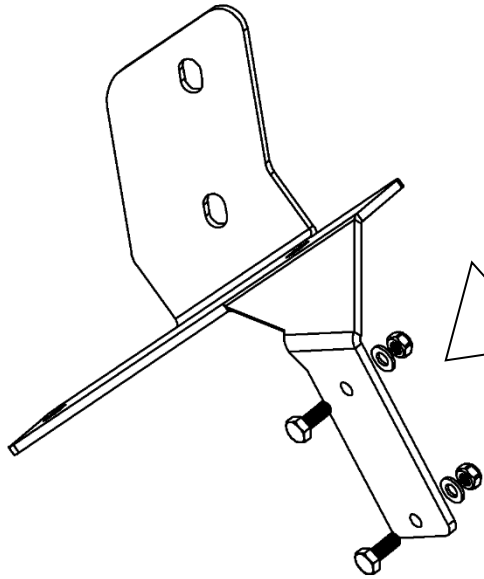

VEHICLE WITH SWAY BAR LINK BRACKET MOUNTED UNDERNEATH, USE THESE TWO HOLES

RESERVOIR MOUNTING SEQUENCE

Left and right are the same. (RH SHOWN)

Fit M6 bolts to mounting bracket and secure with nyloc nut and flat washer. Secure finger tight only at this stage.

Fit the bracket to the vehicle using the sway bar bracket tapped holes and the original hardware as shown in the picture.

Reconnect the sway bar.

Fit the mounting saddle to the reservoir and slide over the heads of the bolts in the mounting plate. Centralise the saddle on the plate and adjust the position of the reservoir as shown.

Ensure the reservoir clears the vehicle parts and that the hose has a clean arc with no kinks.

Note position of reservoir to clamp shown by the photos as a guide.

Fasten hardware securely.

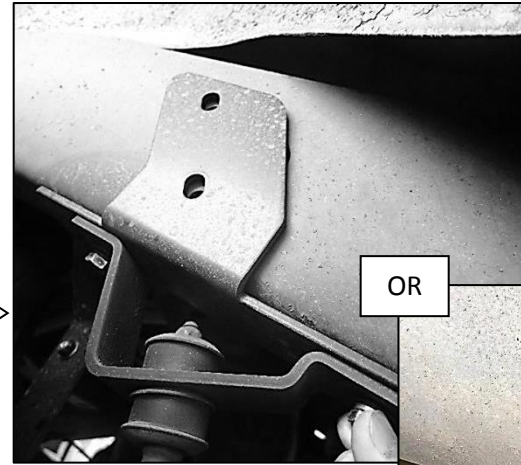

OR

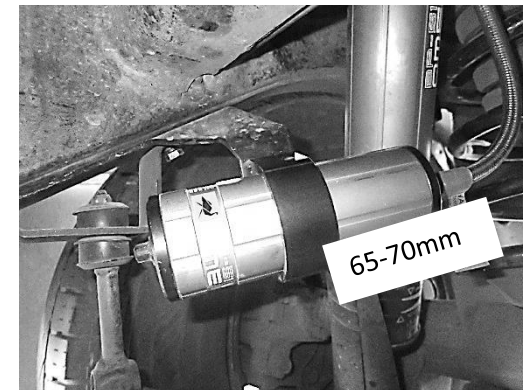

SPECIFICATIONS AND SPARE PARTS

Item	Description	Part No. / Specification
1	Spare Part: Top Bush	VD50010005SP
2	Spare Part: Hose	VD81020225SP
3	Spare Part: Oil	VM80020015
4	Specification: Nitrogen Pressure	2000 kPa
5	Specification: Factory Compression Setting	0
6	Specification: Factory Rebound Setting	3
7	Spare Part: Valve Assy Kit	VM80030001SP
8	Spare Part: Shaft Guard (BP5160013)	VD31010240SP
	Spare Part: Shaft Guard (BP5160015)	VD31010260SP
9	Spare Part: Shaft Guard Retainer	VD31000003SP
10	Spare Part: Bottom Bush	VM50010021SP
11	Spare Part: Damper Mounting Kit	VM80010026

DAMPING ADJUSTMENT

These rear dampers have been set in the factory for a vehicle with no rear load. If your loading differs, use the table below as a guide for recommended compression (Comp) and rebound (Reb) adjuster settings. Refer to the Owners' Manual for more information.

Rear Load	Comp	Reb
0 – 200 kg	0-4	0-4
200 – 400 kg	2-6	4-8
400 – 600 kg	4-8	6-10

Part No.	Lengths (mm)	
	Extended	Compressed
BP5160013	611	388
BP5160015	661	413

