



FITTING INSTRUCTIONS

Part Number: 3550110
 Product: RADAR INSTALL KIT
 Description:
 Suited to: JEEP GRAND CHEROKEE WK2 2011-2014 ON (EXCLUDING SRT8)
 vehicle/s: INCLUDING TRAILHAWK

ARB 4x4 ACCESSORIES

Corporate Head Office

42-44 Garden St
 Kilsyth, Victoria
 AUSTRALIA 3137

Tel: +61 (3) 9761 6622
 Fax: +61 (3) 9761 6807

Australian enquiries
 North & South American enquiries
 Other international enquiries

sales@arb.com.au
 sales@arb.com.au
 exports@arb.com.au

www.arb.com.au

FITTING REQUIREMENTS

REQUIRED TOOLS FOR FITMENT OF PRODUCT:

BASIC TOOL KIT

HAVE AVAILABLE THESE SAFETY ITEMS WHEN FITTING PRODUCT:

Protective eyewear



Hearing protection



NOTE: 'WARNING' notes in the fitting procedure relate to OHS situations, where to avoid a potentially hazardous situation it is suggested that protective safety gear be worn or a safe work procedure be employed. If these notes and warnings are not heeded, injury may result.

FASTENER TORQUE SETTINGS:

SIZE	Torque Nm	Torque lbft
M6	9Nm	7lbft
M8	22Nm	16lbft
M10	44Nm	32lbft
M12 x1.75	77Nm	57lbft
M12 x 1.25	96Nm	71lbft

PARTS LISTING

APPLICATION.	PART NO.	QTY	DESCRIPTION
	3759186	1	BRACKET RADAR WK2 GC JEEP
	3759583	1	BRACKET RADAR WK2 GC JEEP
	6151213	5	BOLT M6 x 1.0 x 20 Gd8.8 BZ
	4581287	7	WASHER SPRING M6 x 2.5 x 1.6 BLK ZN
	4584295	3	WASHER FLAT M6 X 12 X 1.3 BLK ZN
	6151128	3	NUT FLANGE M6 x 1.0 ZP
	6151315	4	NUT CAGED M6 0.7-1.6
	4581082	2	WASHER FLAT, M6 x 19 x 1.6 BZ
	6151443	2	SCREW BTN HD M6 x 20 BZ
	180302	6	CABLE TIE 4.8 X 180 MM BLACK
	6522945	1	PANEL RADAR SURROUND WK2 GC
	3759324	2	BRACKET RADAR COVER PANEL WK2
	2125570	1	WARNING CARD RADAR JEEP WK2

FITTING PROCEDURE

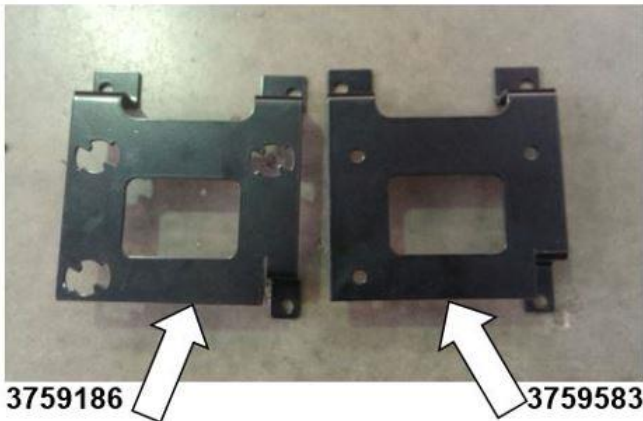

1. There are 2 mounting brackets that can be used for the re-installation of the radar depending on vehicle year model and configuration.

3759186 (left earlier models) and 3759583 (right later models)

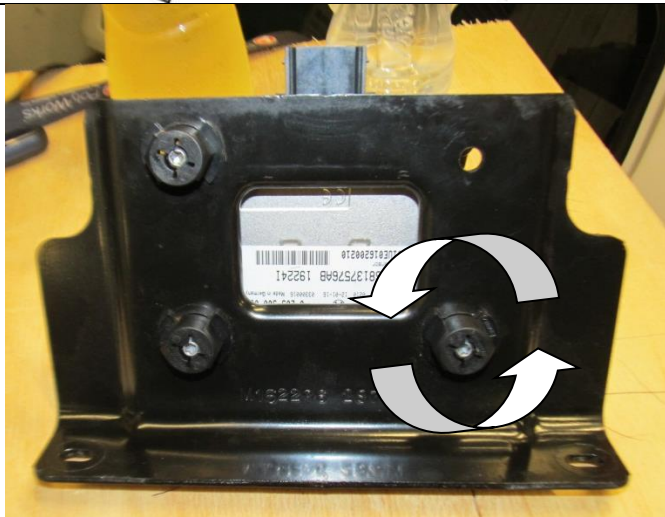

2. If the Radar is fitted using plastic lugs with bracket 3759186 as pictured above proceed to step 4.
3. If Radar is fitted without plastic lugs proceed to step 11.
4. Remove the radar sensor from the OEM bracket by twisting the 3 x black plastic lugs $\frac{1}{4}$ turn anti clockwise which will release the sensor from the bracket and set sensor aside.
5. Remove the plastic lugs from the ends of the radar sensor mount pins and set aside.
6. Discard the OEM bracket.



7. Fit the plastic lugs removed, to the radar sensor bracket (3759186) as shown by inserting the lugs and turning $\frac{1}{4}$ turn clockwise.

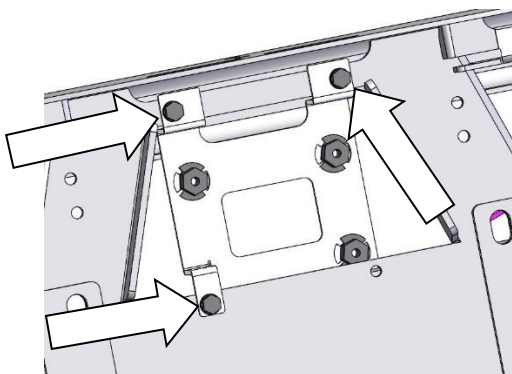

8. Attach the bracket to the bar from the rear as shown using M6 x 20 hex bolts, spring washers, flat washers and flange nuts. Tighten the fasteners to the specified torque.

 M6 - 9 Nm.

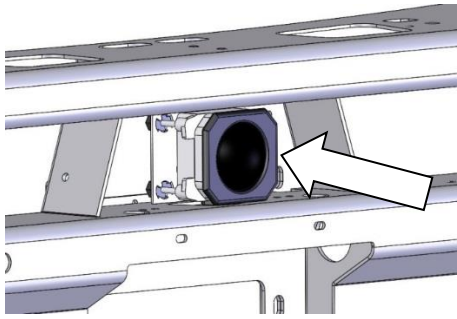

9. Carefully push the radar sensor into the plastic lugs ensuring that they all clip in firmly.
10. Proceed to step 18.

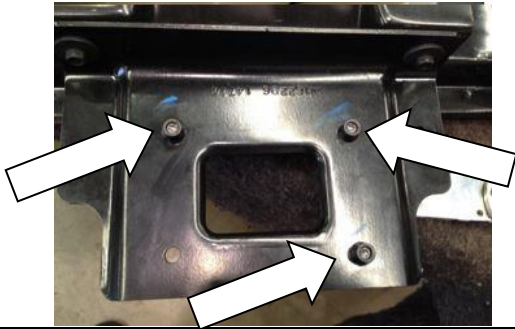

Bracket 3759583 install

11. Remove the radar from the OEM bracket and set aside, retain mounting fasteners.

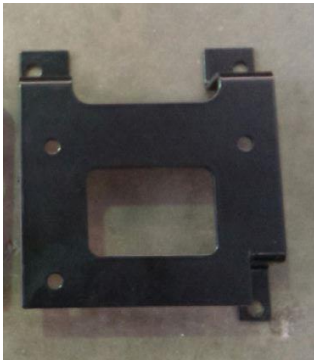

12. Use bracket 3759583 for the installation as pictured.
13. Discard the OEM bracket.

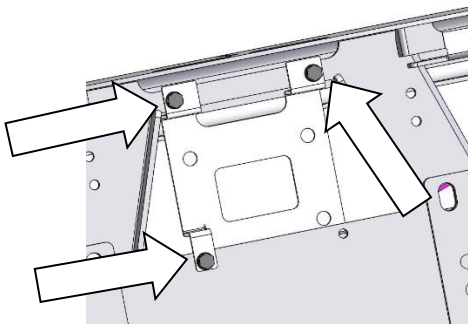

14. Attach the bracket to the bar from the rear as shown using M6 x 20 hex bolts, spring washers, flat washers and flange nuts.
15. Tighten the fasteners to the specified torque.

 M6 - 9 Nm.

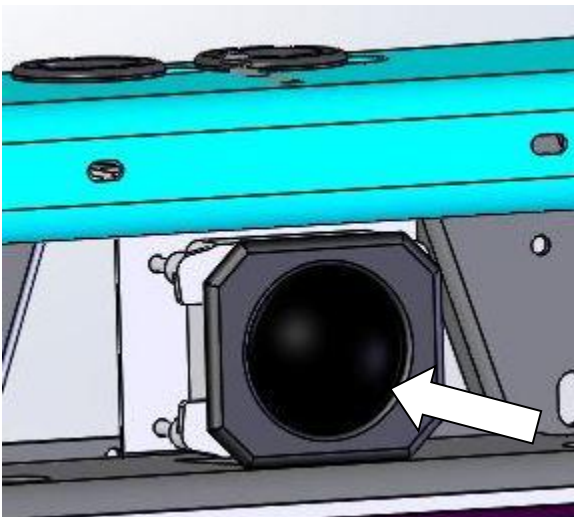

16. Carefully push the radar sensor into the holes of the bracket and using the fasteners removed earlier, fit fasteners to retain the Radar in place

Do not over tighten fasteners.

17. Proceed to step 18.

FITTING PROCEDURE

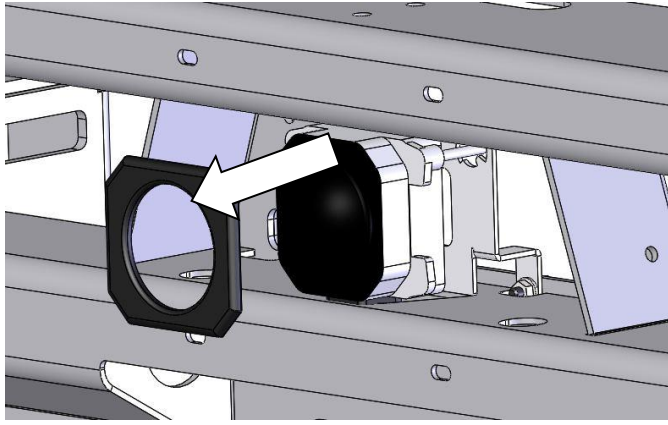

18. Remove the plastic cap from the front of the radar and set aside.

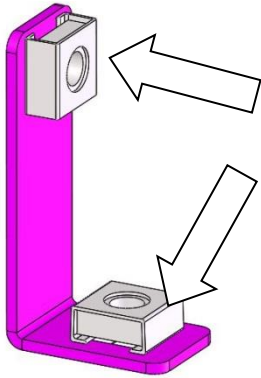

19. Fit 2 x caged nuts to each of the panel brackets as shown

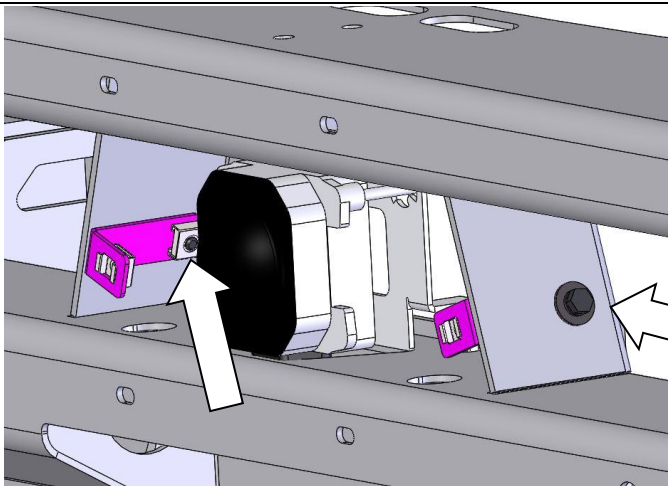

20. Fit the 2 x panel brackets to the inside walls of the winch cradle as shown using 2 x M6 x 20 hex bolts, M6 spring washers and M6 flat washers.

Leave loose at this stage.

FITTING PROCEDURE

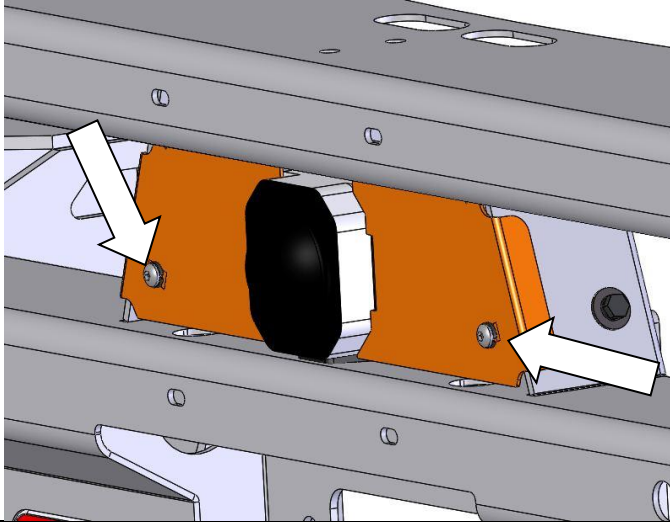

21. Fit the panel over the radar sensor and attach to the panel brackets using 2 x M6 button head cap screws and M6 spring washers.

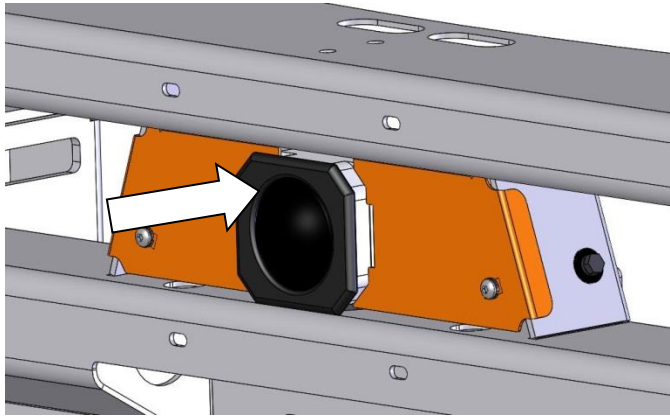

22. Refit the radar cap to the radar sensor.

Return to the bull bar fitting instructions.